

MUTOH

HA-1642

Operation Manual

Operations and Maintenance Methods

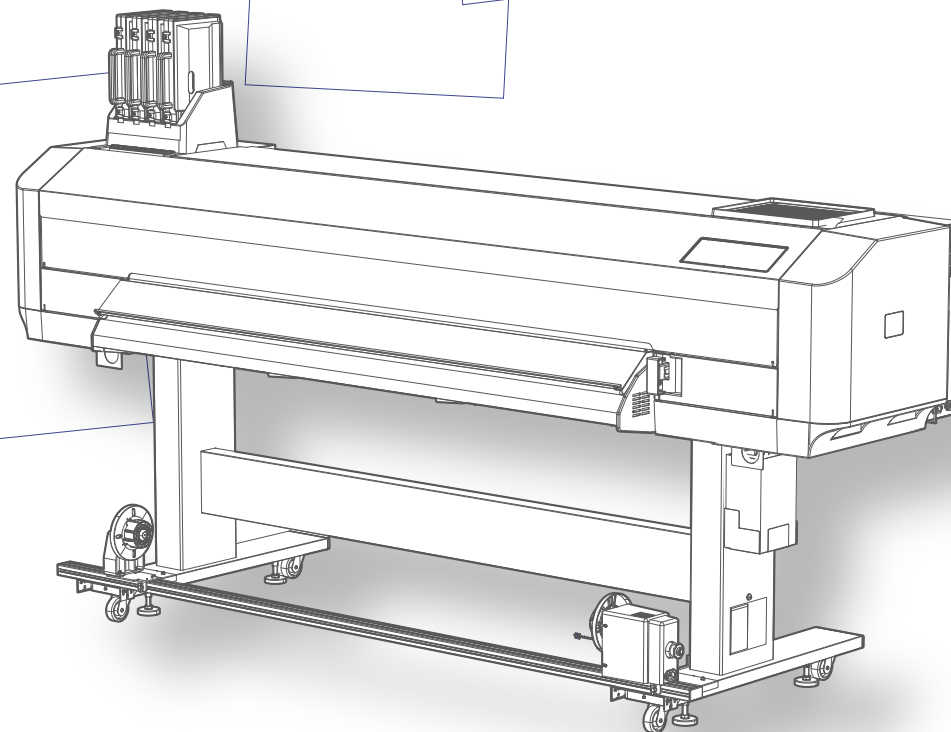

HA1642E-A-00

Important Notice

For Users in Europe



The CE marking is a mandatory European marking for certain product groups to indicate conformity with the essential health and safety requirements set out in European Directives.

By affixing the CE marking, the manufacturer, his authorized

representative, or the person placing the product on the market or putting it into service ensures that the item meets all the essential requirements of all applicable EU directives and that the applicable conformity assessment procedures have been applied.

For Users in the United States

This equipment has been tested and found to comply with the limits for a Class A digital device, pursuant to Part 15 of the FCC Rules. These limits are designed to provide reasonable protection against harmful interference when the equipment is operated in a commercial environment. This equipment generates, uses, and can radiate radio frequency energy and, if not installed and used in accordance with the instruction manual, may cause harmful interference to radio communications.

Operation of this equipment in a residential area is likely to cause harmful interference in which case the user will be required to correct the interference at his own expense.

This system (including the housing and safety device) is a Class 2 laser product.

Laser specifications of this system (including the housing)
Wavelength: 655 nm, maximum output: 1 mW or less, pulse duration: 3 μ s

- Complies with IEC 60825-1 Edition 3.0 (2014-05-15). Complies with FDA performance standards for laser products except for deviations pursuant to Laser notice No.56 dated May 8, 2019.

CAUTION

Use of controls or adjustments or performance of procedures other than those specified herein may result in radiation exposure.

Microsoft® and Windows® are either registered trademarks or trademarks of Microsoft Corporation in the United States and/or other countries.

VerteLith™ is trademark of MUTOH INDUSTRIES LTD.

Company names and product names that appear in this Guide are registered trademarks or trademarks of the respective companies.

-
- Unauthorized copying or duplication of the whole or part of the contents of this Guide is prohibited.
 - Every care has been taken in writing the contents of this Guide, but please contact MUTOH or the dealer you purchased the product from if you find any unclear, erroneous or otherwise unsatisfactory content in the Guide.
 - Please be aware that MUTOH will not be liable in any way for failures or accidents that result from handling or operating the printer according to any procedures other than those set forth in this Guide.

For Safe Use 7

Safety Precautions	8
In the event of abnormal conditions	9
Usage Precautions	10
Warning labels	17
Instruction Labels	21

Before Use 24

Printer main components / Functions	25
Front view	25
Rear view	27
Printer Control Panel	29
About the connecting computer	31
System configurations	32
Launching/ Opening/ Exiting MSM	33
Launching MSM.....	33
Displaying MSM.....	33
Displaying remote panel	34
Exiting MSM	34

Installing VerteLith	35
Printing area	36
Supported media	37
Media size	37
Cautions on handling media	38
Precaution on storing media after use	38
Precautions	39
Please use this printer regularly	39
Please handle ink bag carefully	39
Please conduct maintenance regularly	40
Some parts need to be replaced periodically	40

Basic Operations 41

Printing workflow	42
Power on/off	43
Turn on the printer	43
Turn off the printer	44
Load the media into the printer	45
Loading media into the printer	45
Using the Take-up unit with the printer	57

Nozzle check and head cleaning.....	61
Performing Nozzle Check.....	61
Performing Head cleaning.....	63
Calibrating your printer	65
Start printing	66
Pause / Resume / Cancel a print job.....	71
Advanced settings	72
Print head Height	73
Changing holddown pressure using media feed lever	75
Canceling or reducing pressure rollers individually	76
Operating from the printer control panel	79
Feeding media.....	79
Pause / Resume printing	80
Cancel printing	81
Start printing during warm-up.....	82
Cutting Media	83
Menus you can access while printing	84

Various settings

86

Key operation.....	87
Menu 1: Setup menus.....	89
Print quality calibration (Adjust Print)	97
Media feed adjustment.....	102
Menu 2: Test Print.....	106
Adjust Head	108
Menu 3: Cleaning	111
Menu 4: Menu Option.....	112
Menu 5: System Info.....	113
Menu 6: Sleep mode	114
Menu 7: Initial Settings.....	115
Menu 8: Job status	116
Menu 9: Roll Length Manage	117
Scan.....	119
Menu 10: Media Adjustment	121
Menu 11: CR Maintenance.....	123
Menu 12: Soak Cleaning.....	125

Maintenance 128

About Maintenance	129
Preparations for maintenance	131
Wearing protective equipment	132
Wearing the supplied gloves	132
Checking ink and replacing ink bag	133
Checking ink level	133
When an ink bag is nearing replacement	134
Replace the ink bag	134
Emptying waste ink tank	138
Daily maintenance at the end of work	141
Preparation	142
Procedure	142
Printer maintenance	152
Nozzle check and head cleaning	152
Clean the color sensor	153
Cleaning inside the printer	155
Replace the consumable parts	157
Cleaning Wiper	157
Replace the wiper pad	160
Replace the Cutter	163

Replace the UV-LED unit filter	166
Replace the UV-LED unit glass	168
Replace the flushing box	170
Moving or transporting the printer	172
Transporting the printer	172
Moving the printer	172
Long-term storage	175
Long-term storage	175
Initial ink charging after Longstore cleaning	179

When problems occur 182

Messages and Error Messages	183
Status messages	183
Message type error display and how to deal with it	186
Smartchip Recovery	189
Error requiring reboot	190
Troubleshooting	193
Trouble during installation / initial setup	193
Trouble with operation	195
Media-related problems	196
Printing problems	198
In case of media jam	202

Appendix **205**

Specifications..... **206**

Optional accessories / Consumable supplies..... **209**

Revision history..... **210**

For Safe Use



Safety Precautions

Symbols



In this document, the following symbols are used for the instructions that must be followed to avoid risk of harm to human health or damage to the property.

Please understand the meaning of each mark and use this product safely and correctly.



■ Warnings and cautions

 Warning	Failure to follow the instructions could result in serious injury or death.
 Caution	Failure to follow the instructions could result in minor injury or damage to the product.

■ Actions that must be avoided or instructions that must be followed.

	Indicates an action that must be avoided. A symbol in the sign indicates the prohibited action.
	Indicates an important instruction that must be followed. A symbol in the sign indicates the instruction must be followed.

■ Other symbols

 Important!	Provides information that require special attention or should be followed.
 Note	Provides supplemental or reference information.
	Indicates the link to the reference section.

In the event of abnormal conditions

Warning



- **In the event of abnormal conditions such as smoke or unusual odor, turn off the main power immediately and unplug the power cord.**

Continuing to use the machine under these conditions may result in failure, electric shock, or fire. Once you have confirmed that smoke is no longer being emitted, contact your local dealer or our service office. Never attempt to repair the machine yourself, which is hazardous.

- **If a foreign object, water, or other liquid gets inside the product, immediately turn off the power button and unplug the power plug from the outlet.**



Continuing to use the machine under these conditions may result in failure, electric shock, or fire. Once you have confirmed is no anomalies, contact your local dealer or our service office. Never attempt to repair the machine yourself, which is hazardous.

- **If ink, maintenance cleaner, or waste fluid, gets on skin, wipe it off immediately with a cloth. Then wash with soap and plenty of water. If skin irritation or inflammation occurs, seek medical advice.**
- **If ink, maintenance cleaner, or waste fluid gets into your eyes, immediately flush them with copious amounts of running water for 15 minutes. If irritation or pain is felt in the eyes, seek medical attention immediately. If left untreated, it may cause redness or mild irritation of the eyes.**
- **If ink, maintenance cleaner, or waste fluid is swallowed, do not force vomiting; gargle immediately and seek medical attention immediately. Attempting to force vomiting may cause vomit to enter the trachea.**



Usage Precautions

Handling

Warning

	<ul style="list-style-type: none"> • Do not touch the product when lightning starts. Doing so may cause electric shock. • Do not insert or drop metal or flammable objects into the printer through openings such as vent. This could result in an electrical shock or fire. • Do not block the vent on the product with cloth or other materials. If covered, the inside the product gets hot, resulting in fire. • Do not touch the moving parts. This may cause injury or damage to the product. • Do not sit on or place heavy objects on the product. Failure to do so may result in injury from a fall. • Do not touch the media guide while printing or the heater is in operation. The media guide becomes hot during operation and you could get burn injuries.
	<ul style="list-style-type: none"> • Never modify the product or open any covers secured with screws. This could result in an electrical shock or damage to the printer. Also, modifying or disassembling the product will void the warranty.
	<ul style="list-style-type: none"> • When handling the printer, please note the following: <ol style="list-style-type: none"> 1. Do not stare at the ultraviolet light at close range for long periods of time. This may cause eye damage. 2. Do not expose your skin to ultraviolet light at close range for long periods of time. This may cause skin inflammation. <p>Small amount of UV light (bluish white light) is leaked from the UV-LED unit, but it is minimized to safe level.</p>

Caution

	<ul style="list-style-type: none"> • Do not tilt or give any impact to the product. Doing so may cause the ink inside the printer to leak.
	<ul style="list-style-type: none"> • When handling the front cover or the maintenance cover, always use the following safety precautions: <ol style="list-style-type: none"> 1. Avoid strong airflow from a fan or an air conditioner to install this printer. If not, it may accidentally close the cover. 2. When opening the cover, make sure the cover does not hit anyone or anything.

For Safe Use

Before Use

Basic Operations

Various settings

Maintenance

When problems occur

Appendix

Safety Precautions

Power cords

Warning



- **Do not damage or modify the power cord or power plug. Also, do not place heavy objects on it, heat it, or forcibly bend or pull it.**
The power cord may be damaged, resulting in fire or electric shock.
- **Do not use the power cord if it is damaged or broken or if the core wire is exposed.**
This could result in fire or electric shock.
- **Do not plug the ground terminal into a power outlet.**
This could result in an electrical shock or fire.
- **Do not allow metal or other objects to touch the blade of the power plug.**
This could result in an electrical shock or fire.
- **Do not use extension cords or power strips.**
This could result in an electrical shock or fire.
- **Do not connect an earth wire to the following places:**
 1. Gas pipe: It has potential risks of fire and explosion.
 2. Earth wire of telephone cables or lighting rods: Large current may flow when the lightning strikes.
 3. Water pipe or faucet: It may not work properly if a plastic pipe is connected to the pipe.



- **Do not handle the power plug with wet hands.**
This could may result in electric shock.

For Safe Use

Before Use

Basic Operations

Various settings

Maintenance

When problems occur

Appendix

Safety Precautions



- **Use the Printer with a power supply that meets specifications**
- **Be sure to use the designated power cords.**

Failure to do so could result in an electrical shock or fire. For the designated power cord, please contact your local MUTOH dealer.

1. The power cord should have the protective ground terminal and make sure to plug in securely.
2. Use the power cords which meet the safety standard, voltage and plug shape of the country to use this product.

- **Plug the power cord into a power outlet close to the machine.**
- **Insert the power plug blade securely.**

Incomplete insertion may cause fire or electric shock.

- **When unplugging the power cord, be sure to hold the plug and pull it out.**

Pulling on the power cord may damage the cord, resulting in fire or electric shock.

- **Clean the power plug regularly with a dry cloth.**

Moisture or adhering to accumulated dust may cause a short circuit, fire or electric shock.

- **Unplug the power plug from the outlet when not using the product for an extended period of time.**

Dust buildup on the power plug may cause fire or electric shock.

- **Use the cord clamp to secure the power cord.**  [Startup Guide "Connecting the cables"](#)



- **Plug the power cords into the wall outlet that has the earth connection and make sure to connect the earth.**

If the earth is not connected, an electrical shock or fire may occur.

- **Make sure to connect an earth wire to the earth connection that meets the following requirements:**

1. Earth terminal of power socket.
2. An earth wire with a copper plate which is buried at 650 mm or more in the ground.

Caution



- **When connecting the power cable, check the input voltage of the power outlet and the capacity of the breaker. Also, connect each cable to a separate power source with an independent breaker.**

Connecting to power outlets linked with the same breaker will cause the breaker to trip.

For Safe Use

Before Use

Basic Operations

Various settings

Maintenance







When problems occur

Appendix

Safety Precautions

Maintenance

Caution

   	<ul style="list-style-type: none">• Make sure to wear protective equipment (gloves, goggles or eye protection, protective clothing, mask) when performing a maintenance.
	<ul style="list-style-type: none">• When cleaning the print head, observe the following:<ol style="list-style-type: none">1. Always follow the steps to perform maintenance.2. Do not touch the tip of a cleaning stick with fingers. If finger oil gets on the stick, it will damage the print head.3. Use the designated maintenance cleaner. Use of non-designated one may cause print head failure.4. Use a new cleaning stick. Reusing used cleaning sticks may cause print head failure.• Check that the media guide is cool enough to perform maintenance. Immediately after printing, the media guide is hot. Allow it to cool down for at least 10 minutes and then perform maintenance.
	<ul style="list-style-type: none">• Never touch the print head nozzles when cleaning the parts around the print head. This could damage the print head.• Do not touch the cleaning wiper and the print head capping station with bare hands when cleaning the wiper. If finger oil gets on this, head cleaning cannot be performed properly.• Do not use volatile chemicals such as thinner, benzine or alcohol for cleaning. This may cause damage to the paint or plastic cover.• Do not attempt the following actions during ink charging:<ol style="list-style-type: none">1. Power off the printer and disconnect the power cord.2. Open the front cover or the maintenance cover.3. Raise the pressure rollers.4. Move the printer.

For Safe Use

Before Use

Basic Operations

Various settings

Maintenance

When problems occur

Appendix

Safety Precautions

Location of the Printer

Warning



- **Install in a well-ventilated area and ensure that the work area is well ventilated.**
Odor of ink could have adversely impact on health. If you experience headache, fatigue or dizziness, stop your work and immediately get to fresh air. If nausea persists, seek medical advice.
- **Before taking out the printer from the packaging box, remove the plastic sheet wrapped around the printer first.**
Failure to do so may cause slip or damage to the product.

Caution



Choose the location which satisfies the requirements below:

1. The floor must be level.
2. Avoid vibration from the neighboring devices.
3. Low humidity and free from dust.
4. Less chance of temperature and humidity changes.
5. Avoid direct sunlight.
6. Avoid water.
7. Avoid direct air onto the printer.
8. Low levels of electromagnetic waves.



- **This equipment is not suitable for use in locations where children are likely to be present.**
- **Next to the UV-LED lamp in the printer, there may be other sources of UV light present in the working environment: sunlight or any form of artificial light. It could cause unintended curing, resulting in printer damage (nozzle clogs, malfunction of the maintenance station, etc.) .Do not install the product in direct sunlight or remove the cover.**

When moving the printer

Caution



- **Before moving this printer, always empty the waste ink tank even moving short distance.**
Failure to do so may result in damage to the product.
- **Minimum three people are required for moving this product. When moving, keep the product level. Otherwise proper operation cannot be guaranteed after moving.**
- **Wearing safety shoes is recommended for moving this product.**

For Safe Use

Before Use

Basic Operations

Various settings

Maintenance







When problems occur

Appendix

Safety Precautions

Ink and waste fluid

Warning

	<ul style="list-style-type: none">• The safety concerns involved with using and handling of ink and waste fluid are detailed in the Safety Data Sheet (SDS). Please read the SDS carefully before handling these liquids. Please download the latest SDS from our website (https://www.mutoh.co.jp/en/).
   	<ul style="list-style-type: none">• Always wear protective equipment (gloves, goggles or safety glasses, protective clothing, mask) when handling ink or performing any work that ink may come in contact with your skin (e.g. cleaning print heads, caps, wipers, etc.).• Two types of gloves are supplied with the printer. To avoid ink penetration, please wear rubber gloves (white) over polyethylene gloves (pink). If these gloves are not available, butyl rubber gloves are recommended.• If glove becomes contaminated with ink, replace with new ones.• Do not touch uncured ink with bare hands. Ink curing time varies depending on the surface characteristics of media. Always wear gloves when checking if the ink has cured.
	<ul style="list-style-type: none">• Store ink in a cool, dark place and keep away from fire and heat.

For Safe Use

Before Use

Basic Operations

Various settings



Maintenance

When problems occur

Appendix

Safety Precautions

Caution

	<ul style="list-style-type: none">• Do not disassemble or give strong impact to the ink bag, or swing it around violently. Doing so may cause ink leakage.
	<ul style="list-style-type: none">• Use MUTOH genuine ink. This printer is designed to deliver best performance by using MUTOH genuine ink. The use of non-genuine ink may affect the printer as well as print quality. This is not covered by the warranty.• Use inks within its shelf life.<ol style="list-style-type: none">1. Use of expired ink may cause ink ejection failure or damage to the printer.2. When expired, replace with a new one even if ink remains in the ink bag.3. Dispose of expired ink as industrial waste. Put the emptied ink bag in a plastic bag and dispose of it according to the local regulations.• Ink bags and waste fluid should be stored in the following places:<ol style="list-style-type: none">1. A place out of reach of children.2. A cool, dark place that keeps away from fire, high temperature or direct sunlight.• When disposing of ink, waste fluid collected from the printer, or containers and paper towels with ink adhered, be sure to follow the instructions of industrial waste disposal contractors, related laws, and local regulations to dispose of them.• Waste fluid collected from this printer is harmful. Do not allow it to reach sewage or natural water systems.• Use a HDPE container with light blocking properties to store waste fluid.• When storing waste fluid for a long time, slightly loosen the cap on the container to allow air. Do not tightly close it.• Do not mix waste ink with any other chemical substances, not even in small amounts.• When mixed with other chemicals (e.g. oxidants), heating may occur.

For Safe Use

Before Use

Basic Operations

Various settings

Maintenance

When problems occur

Appendix

Safety Precautions

Warning labels

Warning labels are affixed to the hazardous area of the printer. Read and follow the instructions on the labels. In case the warning labels came off or get dirty, please contact your local MUTOH dealer for replacement.

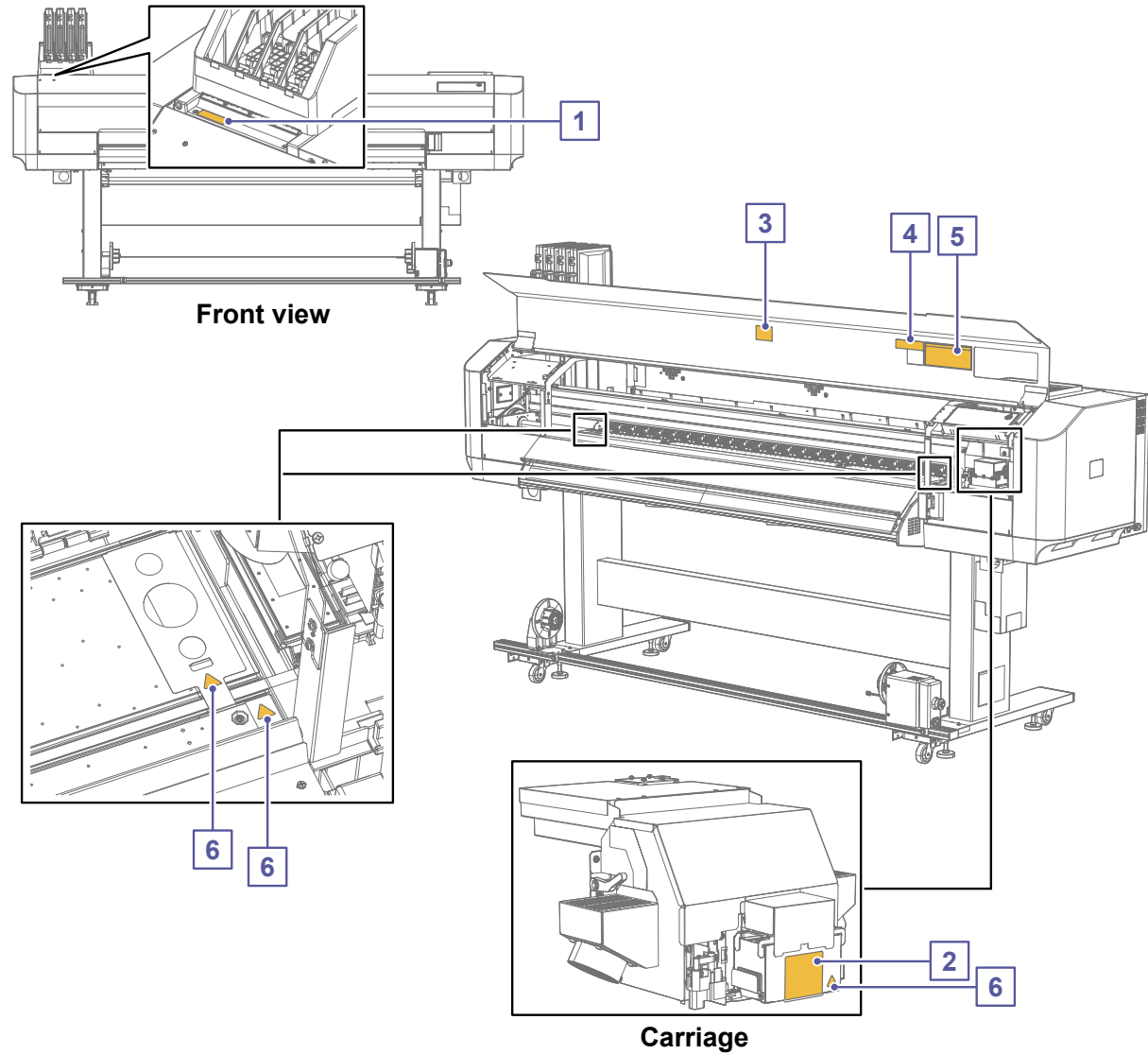

For Safe Use

Before Use

Basic Operations

Various settings

Maintenance

When problems occur

Appendix

Safety Precautions

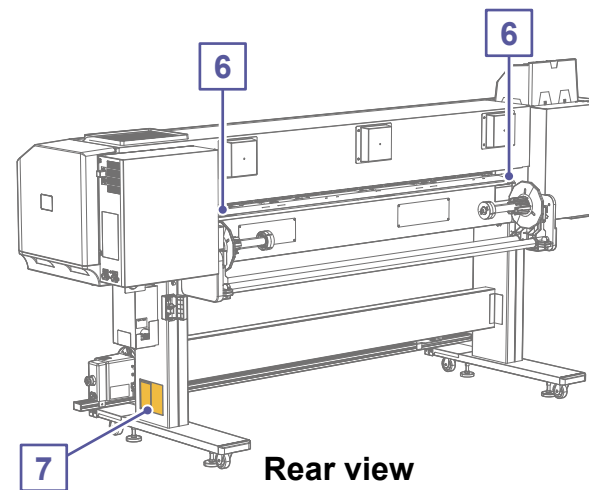

Rear view

Note

The following marks correspond to Chinese safety standards.



汉文	仅适用于海拔2000m以下地区安全使用。
藏文	《2000m རྒྱུ་མཚོའི་དོན་ལས་མཐོ་ཚད་ལྷོ་2000མན་གྱི་ས་ཁྲུལ་ཁོ་ན་ར་ཉེན་མེད་བེད་སྤྱོད་བྱས་འཇུགས།》
蒙古文	“ “ རྒྱ་མཚོའི་དོན་ལས་མཐོ་ཚད་ལྷོ་2000མན་གྱི་ས་ཁྲུལ་ཁོ་ན་ར་ཉེན་མེད་བེད་སྤྱོད་བྱས་འཇུགས།”
壮文	Dan hab yungh youq gij digih haijbaz 2000m doxroengz haenx ancienz sawjyungh.
维文	دېڭىز يۈزىدىن 2000 مېتر تۆۋەن رايونلاردا بىخەتەر ئىشلەتكىلى بولىدۇ



汉文	“仅适用于非热带气候条件下安全使用。”
藏文	《གློ་ལྷུ་ལྔ་ལྗང་གི་མཐོའི་ལྗང་གི་ས་ཁྲུལ་ཁོ་ན་ར་ཉེན་མེད་བེད་སྤྱོད་བྱས་འཇུགས།》
蒙古文	“ “ ཚོ་བའི་ས་ཁྲུལ་གྱི་གན་མ་གཤིས་མེན་པའི་ས་ཁྲུལ་ཁོ་ན་ར་ཉེན་མེད་བེད་སྤྱོད་བྱས་འཇུགས།”
壮文	Dan hab yungh youq gij dienheiq diuzgen mbouj dwg diegndat haenx ancienz sawjyungh.
维文	غەيرى ئىسسىق بەلباغ ھاۋا كىلىماتى شارائىتىدا بىخەتەر ئىشلەتكىلى بولىدۇ

For Safe Use

Before Use

Basic Operations





Various settings

Maintenance

When problems occur

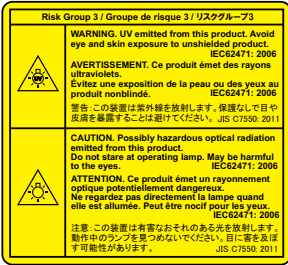
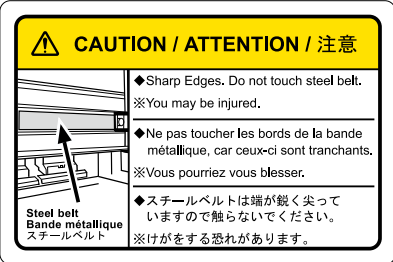
Appendix

Safety Precautions

	Label type	Name/Meaning
1		Protective equipment wear label <ul style="list-style-type: none"> Wear protective equipment when handling ink.
2		UV warning label <ul style="list-style-type: none"> UV light hazard: Avoid direct skin or eye exposure to light.
3		Steel belt caution <ul style="list-style-type: none"> Do not touch this part to avoid injury.
4		Cutter caution <ul style="list-style-type: none"> Do not place fingers near the cutter. There is a risk of injury from the cutter blade.
5		Front cover caution <ul style="list-style-type: none"> Follow the instructions on the label.
6		Hot surface hazard label <ul style="list-style-type: none"> Risk of burns. Do not touch this surface for at least 10 minutes after printing.

For Safe Use

Before Use

Basic Operations

Various settings

Maintenance

When problems occur

Appendix

Safety Precautions

Label type

Name/Meaning

7



Waste fluid caution label

- Waste ink is harmful to human body. Wear a protective mask, protective glasses, protective gloves, and protective clothing while handling.

For Safe Use

Before Use

Basic Operations

Various settings

Maintenance

When problems occur

Appendix

Safety Precautions

Instruction Labels

Instruction labels are affixed where special attention for operating this product is required. The contents of each label are shown here.

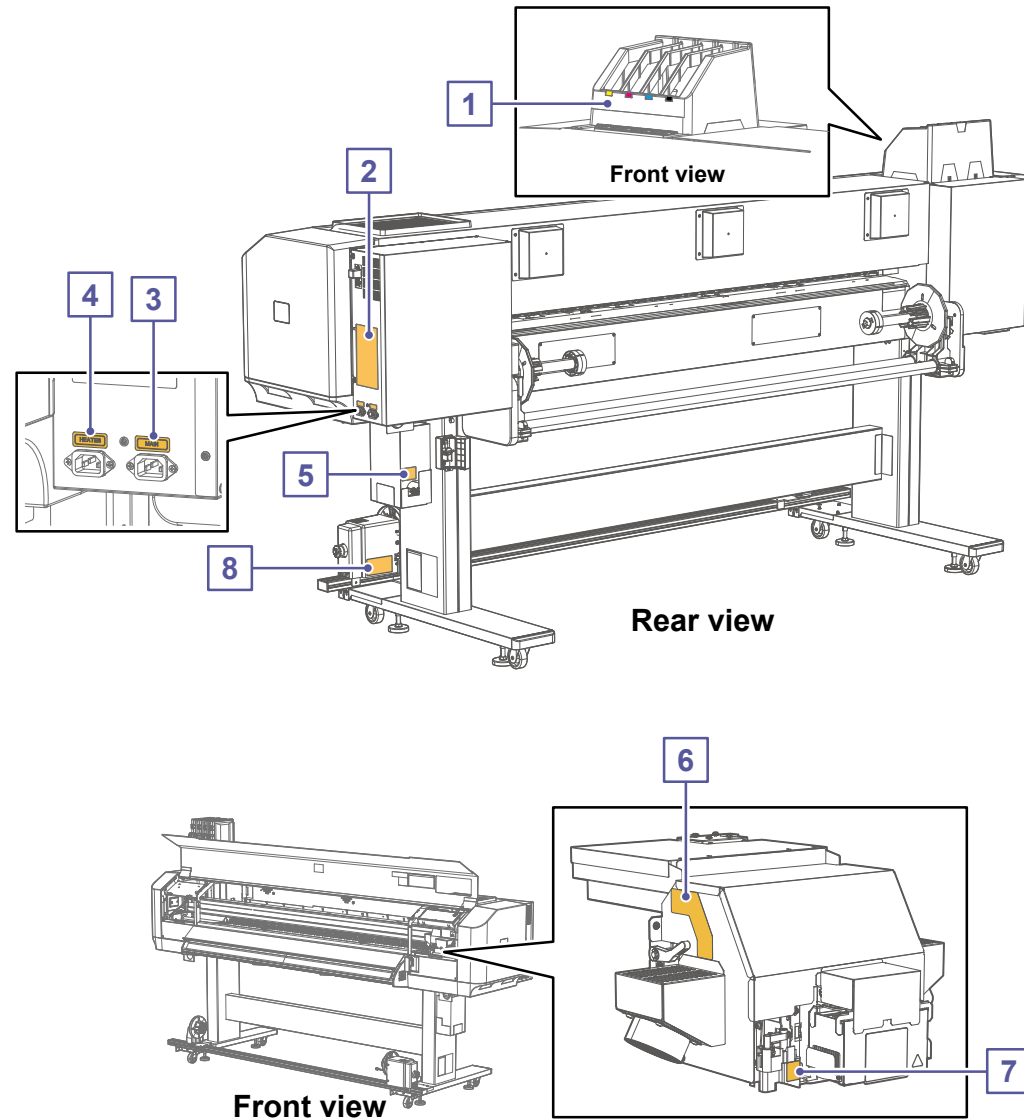

For Safe Use

Before Use

Basic Operations

Various settings

Maintenance

When problems occur

Appendix

Safety Precautions

Label type

Name/Meaning

1



Ink color label

- Make sure to install the color of the ink corresponding to the label.

2



Rating plate

- It contains model, serial number, electrical ratings, certification and notification information.

3



AC inlet label (MAIN)

- Indicates the AC power cable inlet for the printer.

4



AC inlet label (HEATER)

- Indicates the AC power cable inlet for the heater.

5

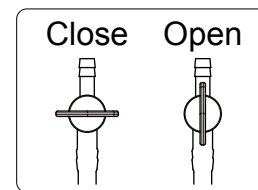

Drain valve label

- Shows the open or close position of the drain valve.

6



PG Label

- Adjust the print head height.

For Safe Use

Before Use

Basic Operations



Various settings

Maintenance

When problems occur

Appendix

Safety Precautions

	Label type	Name/Meaning
7		ORIGIN Label <ul style="list-style-type: none"> Indicates the origin position.
8		Rating plate for take-up unit <ul style="list-style-type: none"> It contains model, serial number, electrical ratings, certification and notification information.

Before Use

Printer main components / Functions	25
About the connecting computer	31
System configurations	32
Launching/ Opening/ Exiting MSM	33
Installing VerteLith	35
Printing area	36
Supported media	37
Precautions	39

Before Use

Basic Operations

Various settings

Maintenance

When problems occur

Appendix

Printer main components / Functions

About the connecting computer

System configurations

Launching/ Opening/ Exiting MSM

Installing VerteLith

Printing area

Supported media

Precautions

Printer main components / Functions

Front view

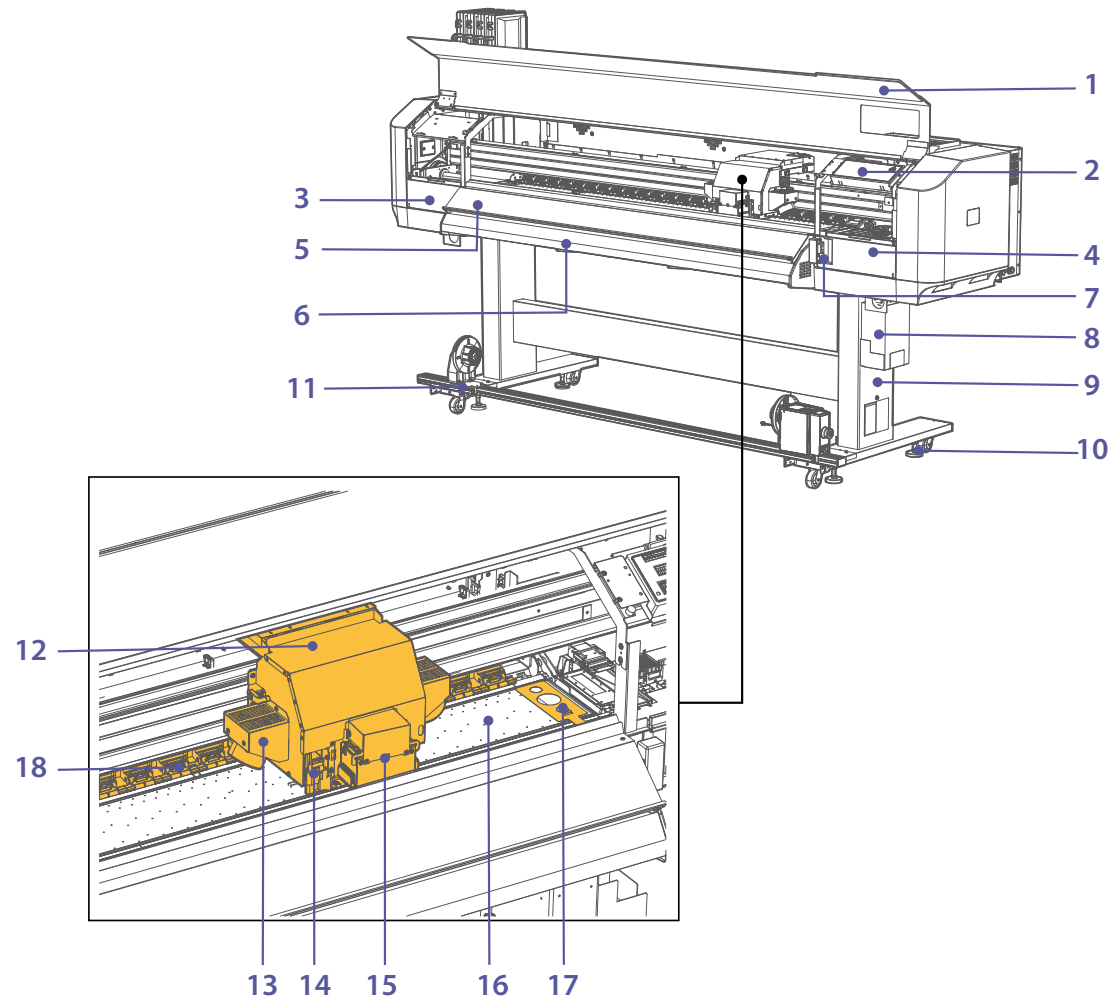

Before Use

Basic Operations

Various settings

Maintenance

When problems occur

Appendix

Printer main components / Functions

About the connecting computer

System configurations

Launching/ Opening/ Exiting MSM

Installing VerteLith

Printing area

Supported media

Precautions

1	Front cover	Opens and closes when loading media or removing jammed paper. Normally, it should be closed.
2	Printer Control Panel	 "Printer Control Panel" P.29
3	Maintenance Cover L	Opens and closes when cleaning or replacing consumables. Normally, it should be closed.
4	Maintenance Cover R	Opens and closes when cleaning or replacing consumables. Normally, it should be closed.
5	UV-LED light protective cover	This cover protects eyes from UV light.
6	Media guide	A roll media passes over the media guide. A heater is built in to dry the ink.
7	Media feed lever	Lever to hold down or release the media. Push the lever to hold down the media. The holddown pressure can be changed between "Normal" and "High" using this lever.
8	Waste ink tank	Collects waste fluids from the printer. Empty the tank before it becomes full.
9	Stand	This supports the main body of the printer.
10	Adjuster	This is used to adjust the height of the printer or prevent shaking.
11	Take-up unit	Rewinds printed media.
12	Carriage	The print head is built in. It moves left and right during printing.
13	Dryer unit	Used to cure ink.
14	Cutter	Automatically cut media.
15	UV-LED unit	This unit irradiates UV light (ultraviolet light) to cure the ink.
16	Platen	Media are printed on this position. The vacuum fan that holds down media and the heater that reduces ink bleeding are built in.
17	Edge holder	Place it on both ends of the media to prevent the media from lifting.
18	Pressure rollers	Holds the entire media from above during printing. The slide lock lever on each pressure rollers can be used to reduce or cancel the holddown pressure.

Before Use

Basic Operations

Various settings

Maintenance

When problems occur

Appendix

Printer main components / Functions

About the connecting computer

System configurations

Launching/ Opening/ Exiting MSM

Installing VerteLith

Printing area

Supported media

Precautions

Rear view

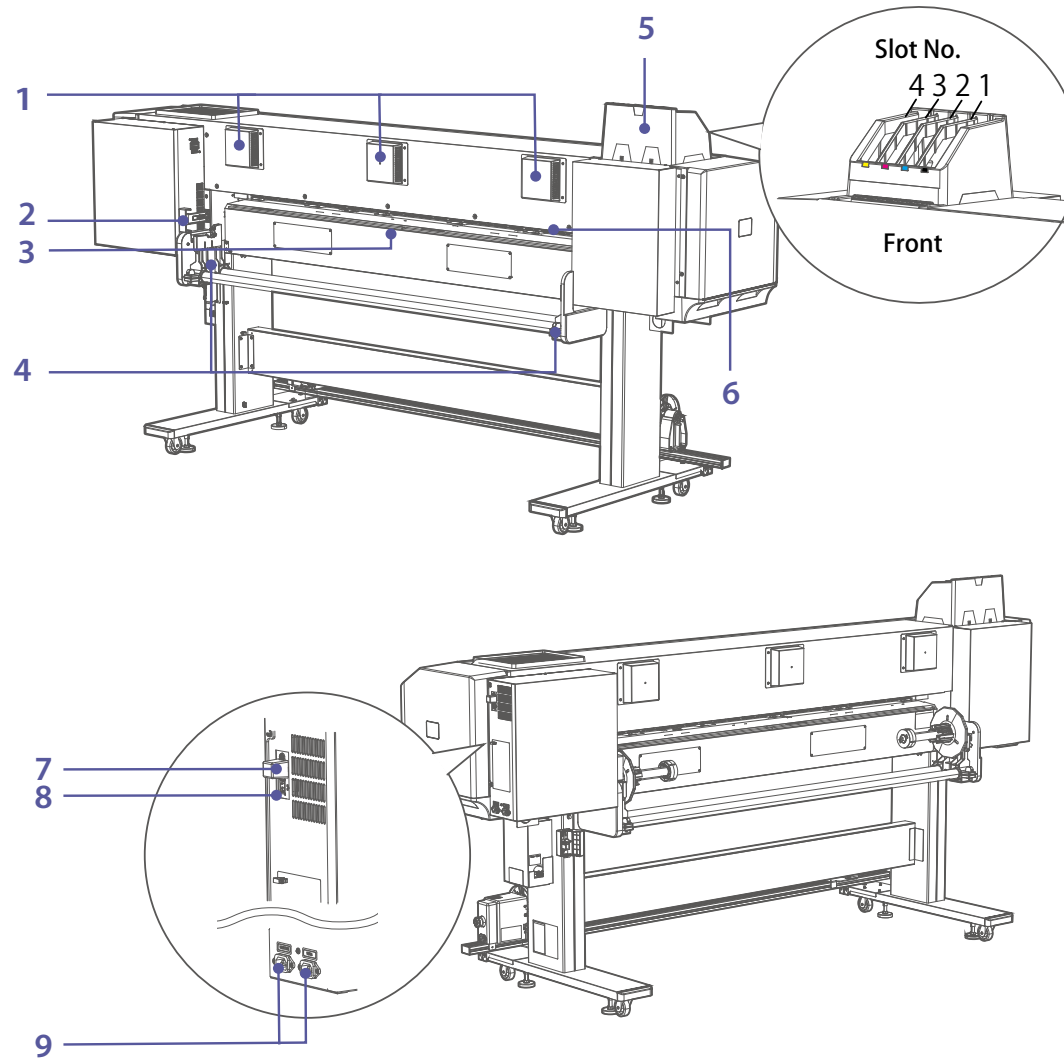

Before Use

Printer main components / Functions

Basic Operations

About the connecting computer

Various settings

System configurations

Maintenance

Launching/ Opening/ Exiting MSM

When problems occur

Installing VerteLith

Appendix

Printing area

Supported media

Precautions

1	Exhaust Fan	Remove exhaust from the air inside the printer.
2	Media feed lever	Lever to fix or release the media. It is linked to the media feed lever on the front side.
3	Media guide	Media Pathways. A built-in heater preheats the media before printing to control media temperature changes.
4	Roll media holder	Load the paper roll. Attach the flange to the roll paper and set it in the roll media holder.
5	Ink slots	Set the ink pack case.
6	Media feed slot	When loading media, insert the media here and pass the media through the front.
7	Take-up unit connector	This connector is used to connect the take-up unit to the printer.
8	Network interface cable connector	Connect the Ethernet cable and use it to connect the printer to the computer.
9	AC inlet	Connect the power cable. To prevent the power cable from disconnecting, secure it to the cable clump.

Before Use

Basic Operations

Various settings

Maintenance

When problems occur

Appendix

Printer main components / Functions

About the connecting computer

System configurations

Launching/ Opening/ Exiting MSM

Installing VerteLith

Printing area

Supported media

Precautions

Printer Control Panel



How to use the printer control panel

The printer has a touch-screen panel. The active keys are lit up on the panel for guidance.

- Tap: Lightly touch the key and immediately release your finger.
- Long touch: Press and hold the key.

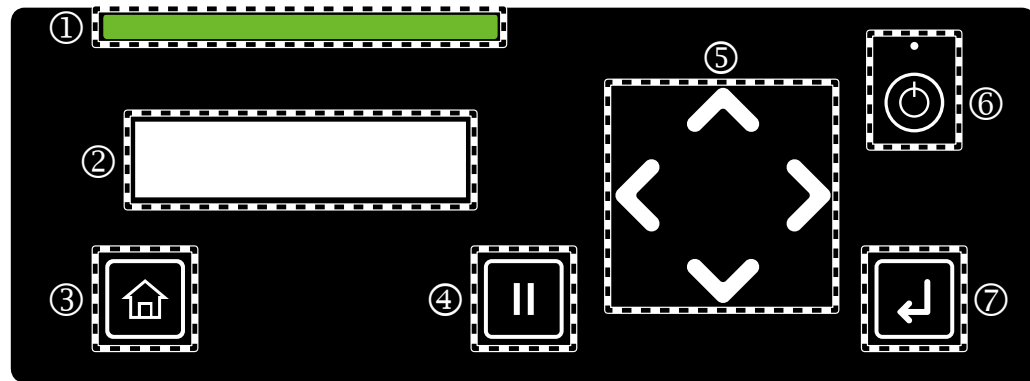
About the parts of the printer control panel



- | | | |
|----------|---|--|
| 1 | Status light | Indicates the printer status by LED light. <ul style="list-style-type: none">• Working normally: Solid green• Error state: Solid red |
| 2 | Display | Displays printer status, setup menus, errors, etc. |
| 3 |  | [Home] key: <ul style="list-style-type: none">• Tap to access to or exit the setup menus. |
| 4 |  | [Cancel] key: <ul style="list-style-type: none">• Tap to pause printing. Tapping the key again will resume printing.• Tapping the key while no printing is performed will cut a sheet off the roll media. |

Before Use

Printer main components / Functions

Basic Operations

About the connecting computer

Various settings

System configurations

Maintenance

Launching/ Opening/ Exiting MSM

When problems occur

Installing VerteLith

Appendix

Printing area

Supported media





Precautions

5









Arrow keys:

In the Setup menu, use these keys to select a menu item or enter a value.

-  Key: Scroll up the menu list.
-  Key: Return to the previous menu without saving the change.
-  Key: Go to the next level menu.
-  Key: Scroll down the menu list.



In ready-to-print state, use these keys to feed media or perform nozzle check print or cleaning.

-  Key: Feed the media backward. Long-touch to feed it with high speed.
-  Key: Print a nozzle check F pattern.  ["Performing Nozzle Check" P.61](#)
-  Key: Perform a cleaning cycle.  ["Performing Head cleaning" P.63](#)
-  Key: Feed the media forward. Long-touch to feed it with high speed.

6



Power button:

- Press and hold the button for more than 2 seconds to turn on the power. The small LED above the button will turn on white.
 ["Turn off the printer" P.44](#)
- Press and hold the button for more than 2 seconds while the power is on to turn the power off. The LED above the button will turn off.
 ["Turn off the printer" P.44](#)

Note

 Mark means standby. The printer consumes a small amount of power when the power cord is connected, even when the white LED above the button is off. In this manual, this state is referred to as the power being off..

7



[Enter] key:

Tap to confirm the menu or the value selected.

- Tapping during warm-up will start printing before warm-up is complete.

Before Use

Printer main components
/ Functions

Basic
Operations

About the connecting
computer

Various
settings

System configurations

Maintenance

Launching/ Opening/
Exiting MSM

When problems
occur

Installing VerteLith

Appendix

Printing area

Supported media

Precautions

About the connecting computer

Important!!

Computers must meet the following requirements

OS: Windows 11, Windows 10

CPU: Intel (R) Core (TM) i5 or higher

Memory: 8 Gbytes or more

Network: Use a network port that supports Gigabit Ethernet, and an Ethernet cable that supports Category 6 Gigabit Ethernet or later.

Note

- The OS support period of MUTOH software follows the Microsoft support lifecycle policies.
- When using RIP software, please also check the system requirements of your RIP software.
- If you are using the LAN connection, make sure that your printer and computer are on the same subnet

Before Use

Printer main components / Functions

Basic Operations

About the connecting computer

Various settings

System configurations

Maintenance

Launching/ Opening/ Exiting MSM

When problems occur

Installing VerteLith

Appendix

Printing area

Supported media

Precautions

System configurations

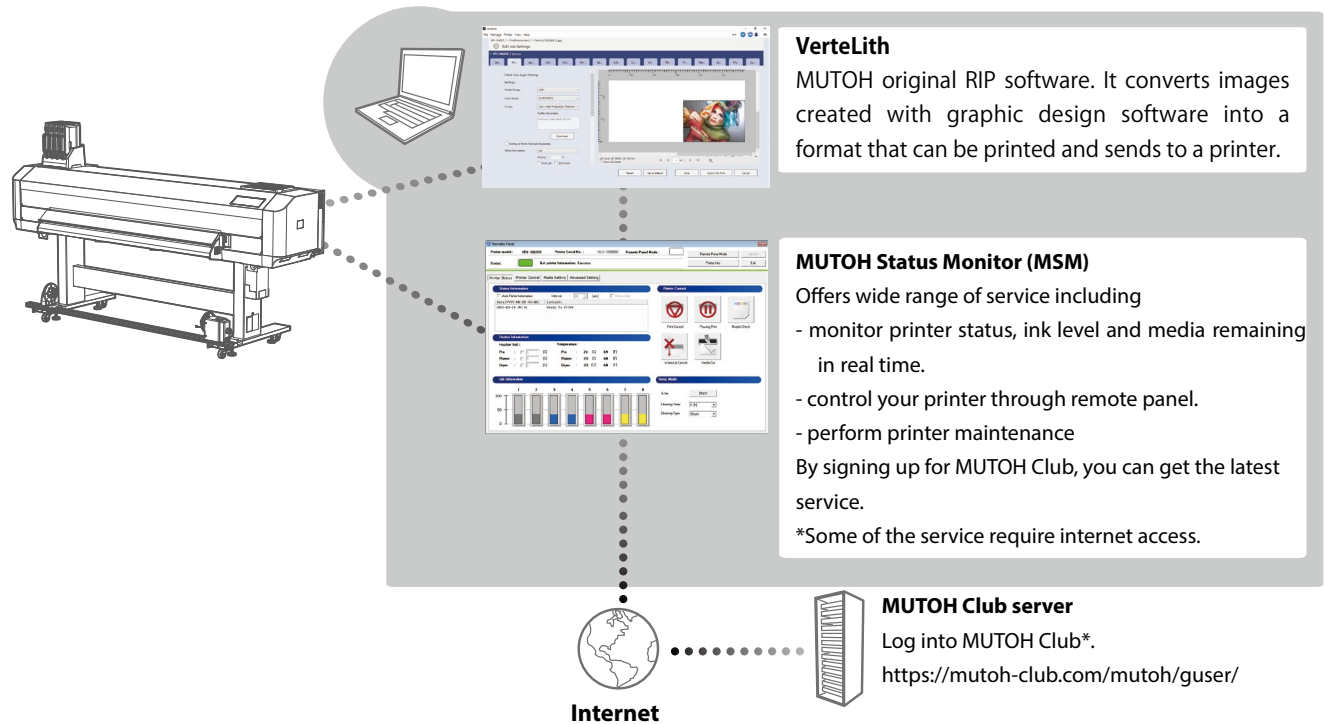

* MUTOH Club

- By signing up for MUTOH Club, it offers free useful contents including
- download the latest version of application, operation manual
 - download media profile
 - check printer information
(printer information uploaded through MSM can be viewed)

<About Printing Support Software>

To get the best out of this product, use the MUTOH Status Monitor (MSM).

You can download the latest version of MSM from the MUTOH Club Server. (To use MPS, specify the output port of RIP software to MPS.)

Before Use

Printer main components
/ Functions

Basic Operations

About the connecting
computer

Various settings

System configurations

Maintenance

Launching/ Opening/
Exiting MSM

When problems occur

Installing VerteLith

Appendix

Printing area

Supported media

Precautions

Launching/ Opening/ Exiting MSM

Launching MSM



Windows 11 / Windows 10

1. Double-click the MSM icon on the desktop.

Note

How to start from the Windows Start Menu

Windows 11 / Windows 10

- From the [Start] menu, click [All Programs] (or [All Apps]) - [MUTOH] - [MUTOH Status Monitor].

Displaying MSM

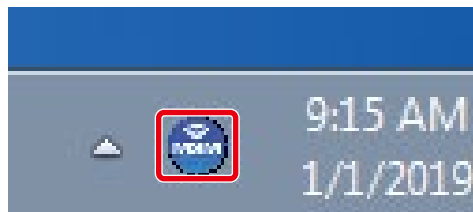

1. Double-click the MSM icon in the task tray.

Before Use

Printer main components / Functions

Basic Operations

About the connecting computer

Various settings

System configurations

Maintenance

Launching/ Opening/ Exiting MSM

When problems occur

Installing VerteLith

Appendix

Printing area

Supported media

Precautions

Displaying remote panel

The remote panel allows you to view the printer status or remotely operate your printer.

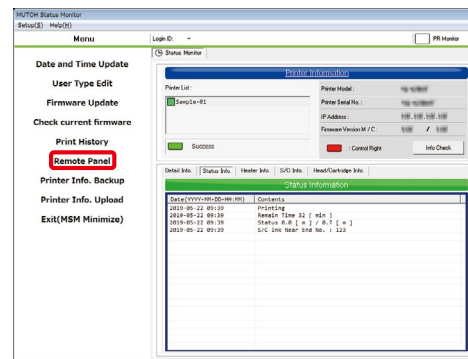

1. Click on the Remote panel.

- The remote panel opens.

Exiting MSM

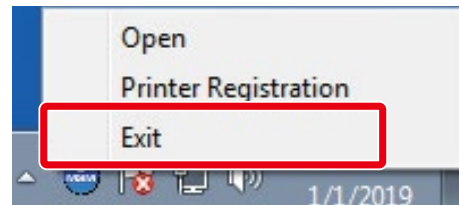

Windows 11 / Windows 10

1. Right-click the MSM icon in the task tray and click [Exit].

Note

While using your printer, do not exit MSM. To close the MSM window, click [Settings] - [Close] on the menu bar.

Before Use

Printer main components
/ Functions

**Basic
Operations**

About the connecting
computer

**Various
settings**

System configurations

Maintenance

Launching/ Opening/
Exiting MSM

**When problems
occur**

Installing VerteLith

Appendix

Printing area

Supported media

Precautions

Installing VerteLith

Follow the instructions on Install Guide supplied with the VerteLith package to complete user registration and installation.

Once installed, follow the VerteLith user manual to complete initial setup and printer registration.

Before Use

Printer main components / Functions

Basic Operations

About the connecting computer

Various settings

System configurations

Maintenance

Launching/ Opening/ Exiting MSM

When problems occur

Installing VerteLith

Appendix

Printing area

Supported media

Precautions

Printing area

The printer always starts printing from the origin position (print start point) with following margin. The illustration below is an example of the printed result.

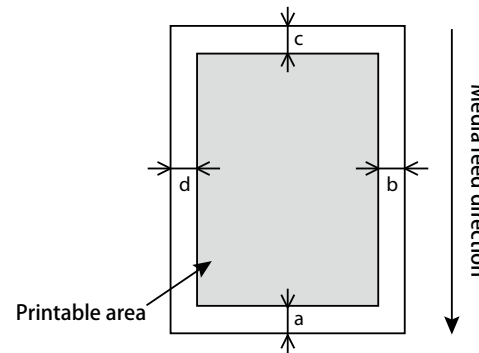

a=5 mm *1
b=5 mm to 25 mm *2
c=5 mm
d=5 mm to 25 mm *2

*1 The margin will be 15 mm in the following cases:

- The first printing after media initialization
- When feeding the media backward by using  key.

The margin will be 40 mm in the following cases:

- When the Media Initial menu is set to "Top&Width"
- After cutting the media

*2 Side margin can be changed from the Side Margin menu

Before Use

Printer main components / Functions

Basic Operations

About the connecting computer

Various settings

System configurations

Maintenance

Launching/ Opening/ Exiting MSM

When problems occur

Installing VerteLith

Appendix

Printing area

Supported media

Precautions

Supported media

Media size

Media outer diameter	up to 200 mm
Media core diameter	2 inches: 50 mm to 52 mm 3 inches: 75.5 mm to 79 mm
Weight	up to 30 kg
Width	500 mm to 1,625 mm
Recommended media thickness	up to 1.0 mm

Important!!

The factory default head height is set to "Low".
In the "Low" setting, media up to 0.3 mm thick can be loaded on the printer.

Note

For recommended media, please contact your local MUTOH dealer.

Before Use

Printer main components / Functions

Basic Operations

About the connecting computer

Various settings

System configurations

Maintenance

Launching/ Opening/ Exiting MSM

When problems occur

Installing VerteLith

Appendix

Printing area

Supported media

Precautions

Cautions on handling media

When handling media, please note the following

- Media should be used in an appropriate environment. The temperature and humidity suitable for printing are as follows

Recommended Printing Environment	Temperature: 22° C to 30° C Humidity: 40% to 60%, no condensation
----------------------------------	--

Change rate	Temperature: within 2° C per hour Humidity: within 5% per hour
-------------	---

- Use media with no fold, scratch, tear or curl.
- The size of media may change according to changes in humidity in the printing environment. Before using media, leave it for 1 hour in the printing environment to adapt it to the environment. If printing is started before the printer is accustomed to the printing environment, paper jams may occur due to misalignment or wrinkling of the printed media. It also has a negative impact on print quality.
- When used in a low-humidity environment, cut media may not fall off depending on how the media is affixed. In such cases, after cutting the media tip, open the front cover and remove the media.
- Do not use heat sensitive media. It will deform during ink curing by UV light.
- Do not touch the printing surface of the media. Moisture and oil on your hands can affect print quality.
- Do not leave media loaded for long periods of time. Some media may become habitual, causing paper lift, paper jams, and poor print quality. Avoid using such media, especially during winter and dry periods.
- Printing on a light reflective material may have a chance to cure the ink on the print head, causing malfunction or damage to the printer.
- Do not discard the original packaging box and plastic bag of roll media. You will use them for storing media.

Precaution on storing media after use

When storing roll media after use, follow these precautions to avoid print defects caused by wrinkles.

- After removing your roll media from the media flange, wind it back onto the roll properly and put it in the original plastic bag. Then store it in the package it came in.
- Avoid high temperature, high humidity, and direct sunlight when storing media.
- Keep the media dry.

Before Use

Printer main components / Functions

Basic Operations

About the connecting computer

Various settings

System configurations

Maintenance

Launching/ Opening/ Exiting MSM

When problems occur

Installing VerteLith

Appendix

Printing area

Supported media

Precautions

Precautions

Please use this printer regularly

It is recommended that printers be used once a week.

If left unattended for a long period of time, the nozzles of the print head will clog, causing a malfunction.

Please handle ink bag carefully

- Before using the ink pack for the first time, be sure to read the Safety Data Sheet (SDS) before carrying out any work.
- Do not disassemble the ink pack.
When decomposed, the ink may get into the eyes or on the skin, causing irritation or allergic reactions.
- Wear gloves, protective glasses, and a mask when handling ink packs.
- When handling ink packs, be careful not to get ink in your eyes or on your skin.
If it gets into eyes or adheres to skin, rinse immediately with water. If left untreated, it may cause redness and mild irritation of the eye. In case of any abnormality, consult a physician immediately.
- Do not drop the ink pack or hit it hard. Ink may leak.
- Ink should be used up within the expiration date.
Expired ink should be disposed of as industrial waste, and empty ink packs should be placed in plastic bags and disposed of in accordance with local ordinances and municipal regulations.
- Use of genuine ink is recommended.
The printers are manufactured to perform at full capacity by using genuine MUTOH inks. Use of non-genuine ink may adversely affect the product itself and print quality.

Before Use

Printer main components
/ Functions

Basic
Operations

About the connecting
computer

Various
settings

System configurations

Maintenance

Launching/ Opening/
Exiting MSM

When problems
occur

Installing VerteLith

Appendix

Printing area

Supported media

Precautions

Please conduct maintenance regularly

Printers require routine maintenance.

- Perform nozzle checks before and after printing.
If the nozzle is clogged, perform head cleaning.
- Please be sure to carry out daily maintenance after the end of the work day. Failure to perform daily maintenance may result in poor image quality or malfunction. [☞ "Daily maintenance at the end of work" P.141](#)
- Clean the cleaning wiper, the outer circumference of the cap, and the outer circumference of the print head once a week.
- If not used for long periods of time*, head cleaning should be performed once a week.
If head cleaning cannot be performed, perform long-term storage. [☞ "Long-term storage" P.175](#)
*When "Not in use for an extended period of time" is defined as leaving it unattended for a week to a month.
- Internal cleaning should be performed once a month.
- Check the waste ink tank regularly and drain the waste liquid before it becomes full.

Some parts need to be replaced periodically

Some parts of the printer will need to be replaced after prolonged use.

- Parts that need to be replaced by the user:
Spitting boxe, cutters, cleaning wipers, absorbent material for wipers, UV-LED unit filters, UV-LED unit glass
- Parts that need to be replaced by service personnel:
Various motors, various pumps, print heads

Basic Operations

Printing workflow 42

Power on/off 43

Load the media into the printer 45

Using the Take-up unit with the printer 57

Nozzle check and head cleaning 61

Calibrating your printer 65

Start printing 66







Advanced settings 72

Operating from the printer control panel 79

Before Use	Printing workflow
Basic Operations	Power on/off
Various settings	Load the media into the printer
Maintenance	Using the Take-up unit with the printer
When problems occur	Nozzle check and head cleaning
Appendix	Calibrating your printer
	Start printing
	Advanced settings
	Operating from the printer control panel

Printing workflow

The basic workflow for printing is as follows

- 1. Turn on the power.**
 ["Turn on the printer" P.43](#)
- 2. Load media into the printer.**
 ["Load the media into the printer" P.45](#)
 ["Using the Take-up unit with the printer" P.57](#)
- 3. Run a nozzle check (perform cleaning if needed)**
 ["Nozzle check and head cleaning" P.61](#)
- 4. Adjust printing accuracy. (When necessary)**
 ["Calibrating your printer" P.65](#)
- 5. Print a design.**
 This section explains how to print using our genuine "VerteLith" RIP software.
 ["Start printing" P.66](#)
- 6. End the printing operation.**
 ["Daily maintenance at the end of work" P.141](#)

Before Use

Printing workflow

Basic Operations

Power on/off

Various settings

Load the media into the printer

Maintenance

Using the Take-up unit with the printer

When problems occur

Nozzle check and head cleaning

Appendix

Calibrating your printer

Start printing

Advanced settings

Operating from the printer control panel

Power on/off

Turn on the printer

1 Close the front cover.

2 Press and hold the power button on the printer for at least 2 seconds.

- The LED above the power button lights up.
- The printer initialization begins.

Note

- When the LED lights up, release the power button.
- The take-up unit rotates during initial operation.



Before Use

Printing workflow

Basic Operations

Power on/off

Various settings

Load the media into the printer

Maintenance

Using the Take-up unit with the printer

When problems occur

Nozzle check and head cleaning

Appendix

Calibrating your printer

Start printing

Advanced settings

Operating from the printer control panel

Turn off the printer

1 Ensure that printing is complete and media has been removed.

2 Press and hold the power button on the printer for at least 2 seconds.

Note

- Tapping  ([Cancel] key) will turn off the printer without performing a daily maintenance.
- Powering off without daily maintenance could cause nozzle clogging. Normally make sure to perform a daily maintenance.

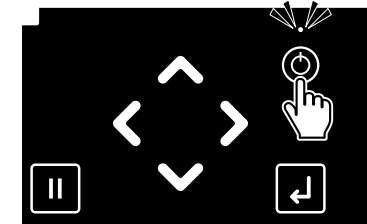

3 Tap  ([Enter] key).

- The carriage moves to the maintenance space on the left side.

Daily Maintenance

Start -> Enter

4 Perform a daily maintenance.

 ["Daily maintenance at the end of work" P.141](#)

5 Once the daily maintenance is done, tap  ([Enter] key).

- "Power Off" appears and the printer turns off. The LED above the power button turns off.

Daily Maintenance

End -> Enter

Before Use

Printing workflow

Basic Operations

Power on/off

Various settings

Load the media into the printer

Maintenance

Using the Take-up unit with the printer

When problems occur

Nozzle check and head cleaning

Appendix

Calibrating your printer

Start printing

Advanced settings

Operating from the printer control panel

Load the media into the printer

Important!!

It is recommended that two or more people work with the media.

Loading media into the printer

Follow these steps to load the media into the printer

1. Attach the flange to the media

What you need:

- Media: 1 piece
- Flange: 2 pcs.

1 Change the flange adapter according to the application.

When using media with an inner diameter of 2 inches;
Remove the 3" adapter from the flange.

- (1): While opening the two claws on the adapter, pull out the adapter.
- (2): Pull out the adapter while opening the three claws on the adapter.

Note

- If the (2) adapter does not come off, refer to step 2 to rotate the flange handle counterclockwise to loosen it, and then perform the procedure again.
- Do not perform this procedure when using media with an inner diameter of 3 inches.

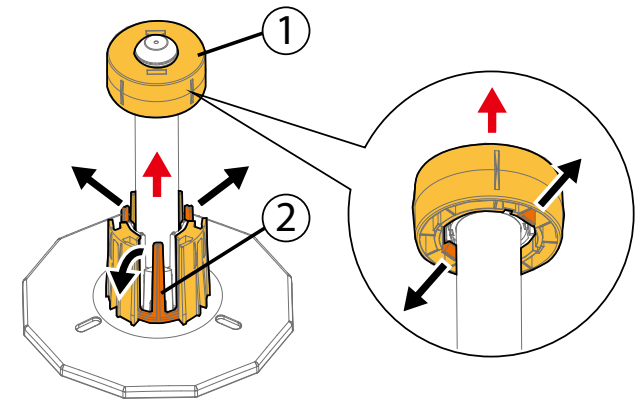

Before Use

Printing workflow

Basic Operations

Power on/off

Various settings

Load the media into the printer

Maintenance

Using the Take-up unit with the printer

When problems occur

Nozzle check and head cleaning

Appendix

Calibrating your printer

Start printing

Advanced settings

Operating from the printer control panel

When changing from 2-inch media to 3-inch media;
Attach the 3-inch adapter to the flange.

- (1): Install the adapter by aligning the adapter's three tabs with the recesses at the base of the flange.
- (2): Attach the adapter by aligning the notches (4) on the inside of the adapter with the protrusions (4) on the end of the flange as shown in the illustration on the left.

Note

- (2) If the adapter is installed without aligning the two adapters, the adapter will not be fixed in place.

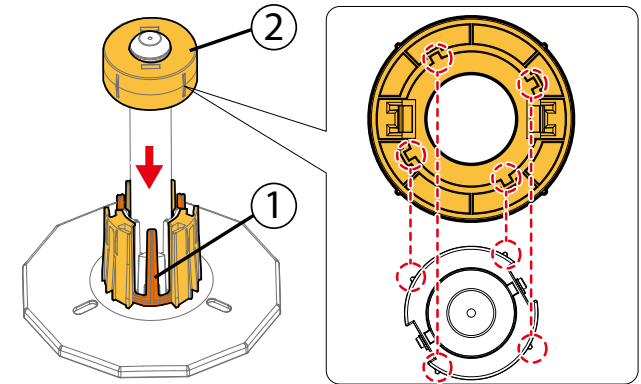

2 Attach (2) flanges on both ends of the media.

- Rotate the flange handle counterclockwise so that it is ready to be attached to the media.

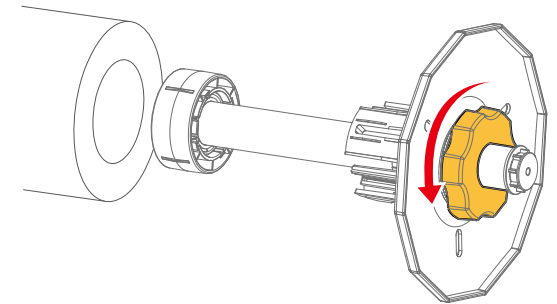

3 Rotate the flange handle clockwise to secure the flange.

Important!

Make sure that the media is firmly secured. If not secured properly, the media may come off the flange during printing, which may affect print quality.

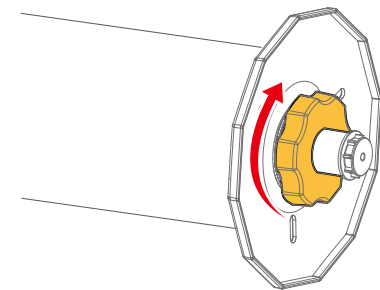

Before Use

Printing workflow

Basic Operations

Power on/off

Various settings

Load the media into the printer

Maintenance

Using the Take-up unit with the printer

When problems occur

Nozzle check and head cleaning

Appendix

Calibrating your printer

Start printing

Advanced settings

Operating from the printer control panel

2. Set the roll media holder torque.

To set the torque on the roll media holder, follow the steps below.

- 1 Loosen the knob bolts on the left and right roll media holders by rotating them counterclockwise.

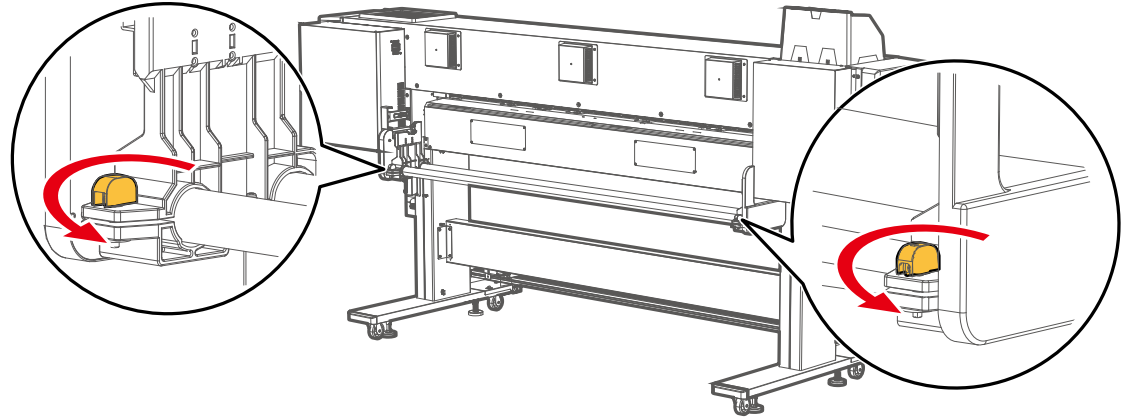

- 2 Move the left and right roll media holders about 30 cm toward the center of the printer.

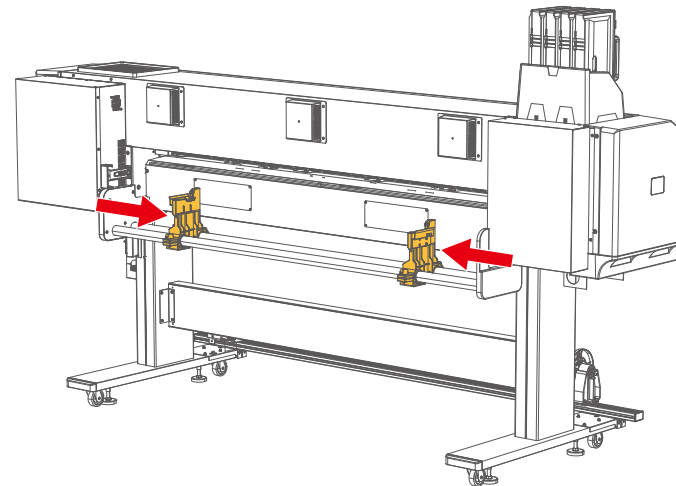

Before Use

Printing workflow

Basic Operations

Power on/off

Load the media into the printer

Various settings

Using the Take-up unit with the printer

Maintenance

Nozzle check and head cleaning

When problems occur

Calibrating your printer

Appendix

Start printing

Advanced settings

Operating from the printer control panel

3 Tighten the knob bolts on the left and right roll media holders.

4 Loosen the screw of the roll axis guide on the roll media holder on the right side facing from the rear with a screwdriver.

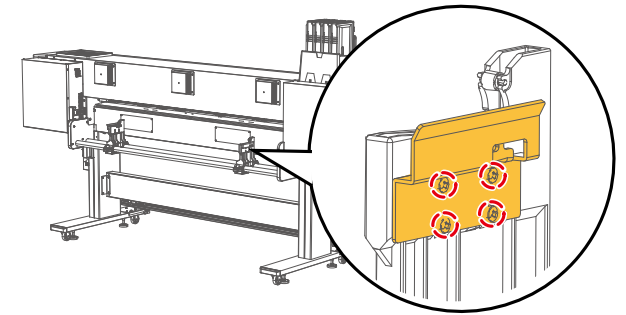

5 Shift the roll axis guide upward and tighten the screw at the point where it hits.

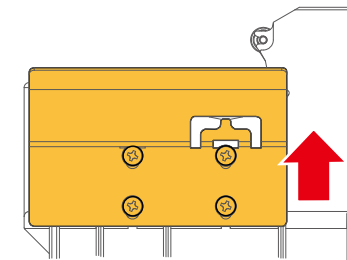

Roll axis guide (right)

6 Shift the roll shaft guide on the roll media holder on the left side in the same manner, and then tighten the screw.

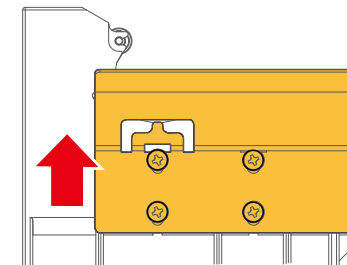

Roll axis guide (left)

Before Use

Printing workflow

Basic Operations

Power on/off

Various settings

Load the media into the printer

Maintenance

Using the Take-up unit with the printer

When problems occur

Nozzle check and head cleaning

Appendix

Calibrating your printer

Start printing

Advanced settings

Operating from the printer control panel

- 7 Loosen the knob bolts on the left and right roll media holders and reposition the left and right roll paper catches.

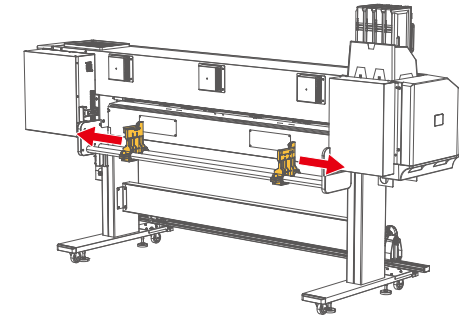

- 8 Tighten the knob bolts on the left and right roll media holders.

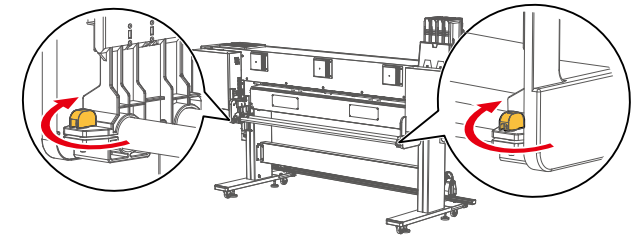

3. Install media in the roll media holder

- 1 Loosen the knob bolt on the right roll media holder by turning it counterclockwise.

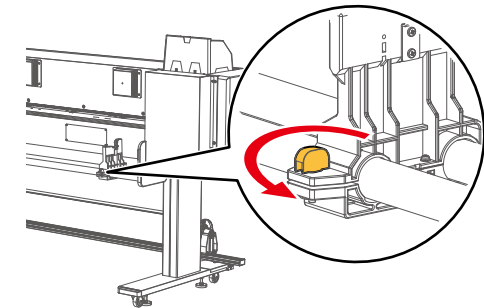

Before Use

Printing workflow

Basic Operations

Power on/off

Various settings

Load the media into the printer

Maintenance

Using the Take-up unit with the printer

When problems occur

Nozzle check and head cleaning

Appendix

Calibrating your printer

Start printing

Advanced settings

Operating from the printer control panel

2 Install the media into the roll media holder on the left side. Install slowly and carefully.

- Set the flange tip between the roll shaft guide and the roll media holder.

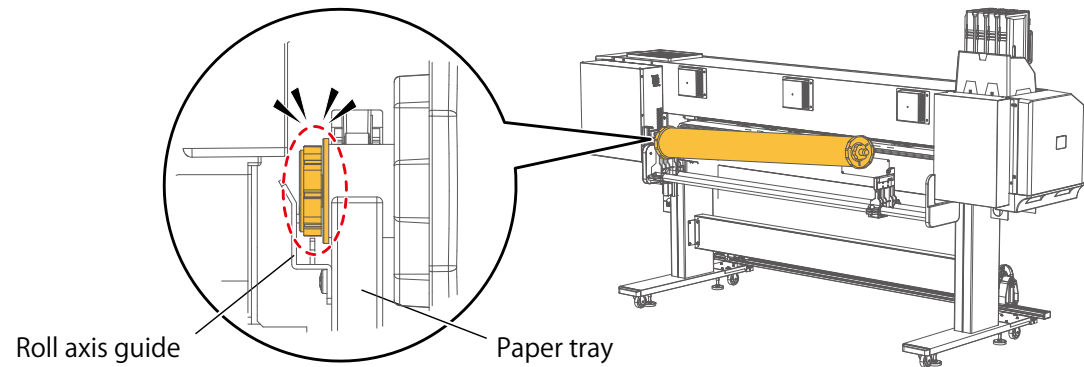

If torque is set, continue to check the following

- (1): Viewed from the straight side, check that the projection of the roll shaft guide is engaged between the projections at the end of the flange.
- (2): Viewed from the rear, check that the projection of the roll axis guide is set at the end of the flange.

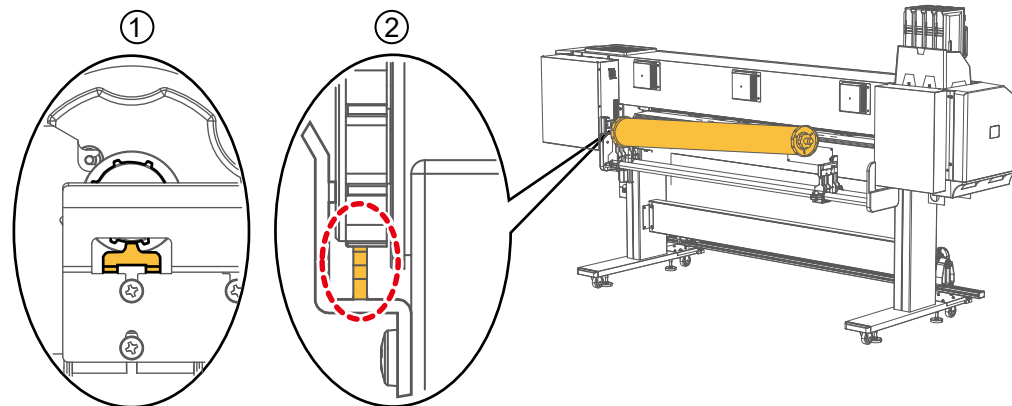

Important!

- Strong impact during media installation may damage parts.
- When moving the roll media holder (left), do not move it more than 450 mm to the right from the left edge. Media detection will be disabled.

Before Use

Printing workflow

Basic Operations

Power on/off

Various settings

Load the media into the printer

Maintenance

Using the Take-up unit with the printer

When problems occur

Nozzle check and head cleaning

Appendix

Calibrating your printer

Start printing

Advanced settings

Operating from the printer control panel

3 Install the media into the roll media holder on the right side. Install slowly and carefully.

- Move the roll media holder on the right side to match the media.
- Set the flange tip between the roll shaft guide and the roll media holder as shown in the illustration below.

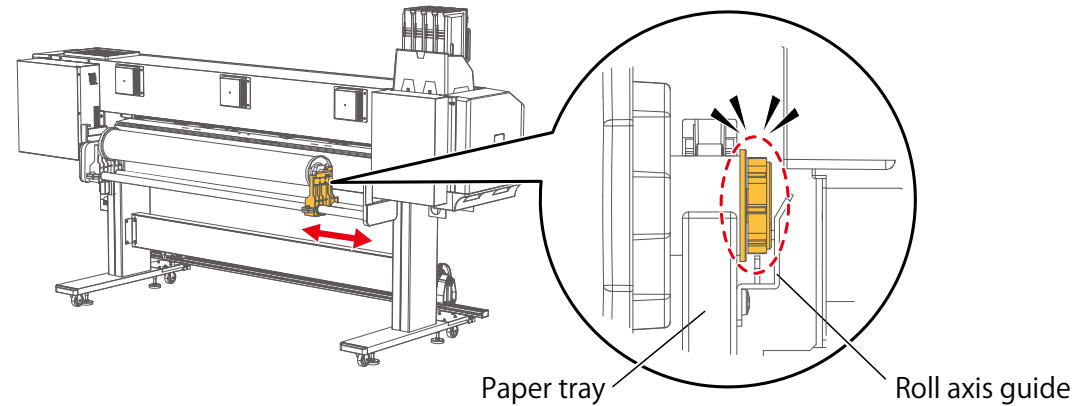

If torque is set, continue to check the following

- (1): Viewed from the straight side, check that the projection of the roll shaft guide is engaged between the projections at the end of the flange.
- (2): Viewed from the rear, check that the projection of the roll axis guide is set at the end of the flange.

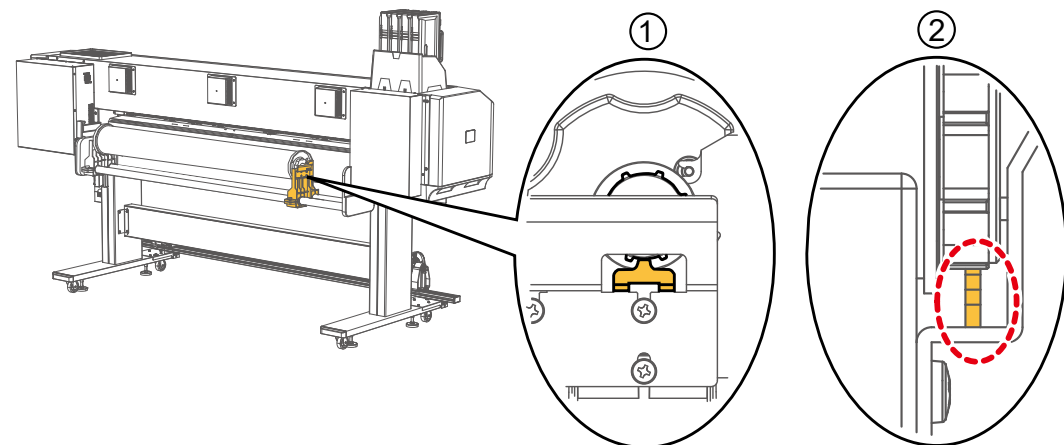

Before Use

Printing workflow

Basic Operations

Power on/off

Load the media into the printer

Various settings

Using the Take-up unit with the printer

Maintenance

When problems occur

Nozzle check and head cleaning

Appendix

Calibrating your printer

Start printing

Advanced settings

Operating from the printer control panel

- 4 Rotate the knob bolt on the roll media holder (right) clockwise to tighten.

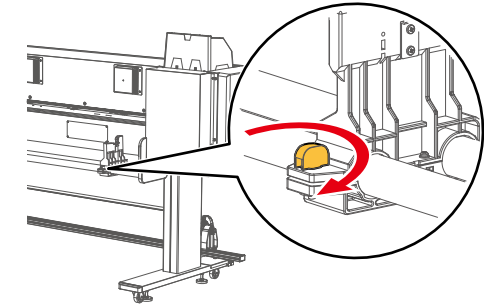

4. Loading media into the printer

- 1 Make sure the printer is turned on.
- 2 Pull the media feed lever to the very front and raise the pressure rollers.

The media feed lever can also be operated from the rear of the printer.

- When pushed in the back, the pressure rollers raises.

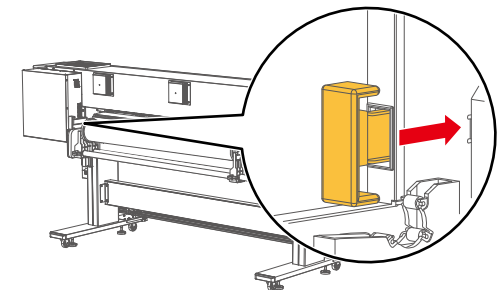
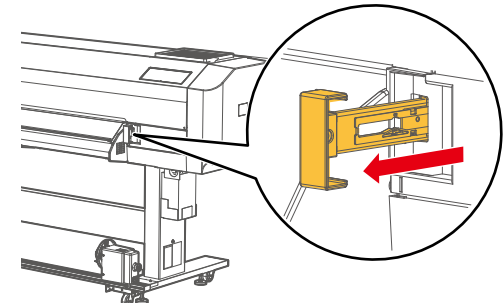

Before Use

Printing workflow

Basic Operations

Power on/off

Various settings

Load the media into the printer

Maintenance

Using the Take-up unit with the printer

When problems occur

Nozzle check and head cleaning

Appendix

Calibrating your printer

Start printing

Advanced settings

Operating from the printer control panel

3 Open the front cover.

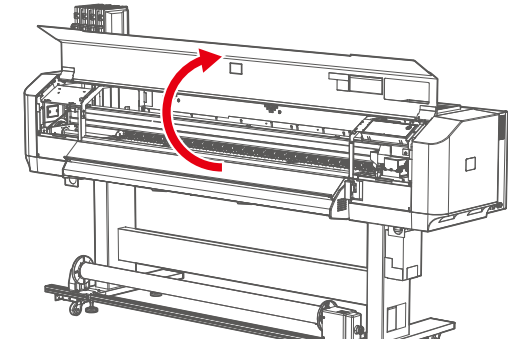

4 Insert the media into the media feed slot.

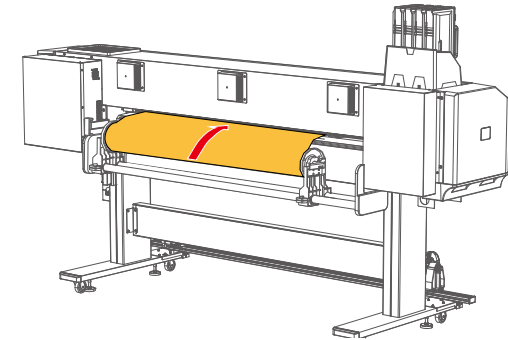

5 Pull out about 1 m of media from the media feed slot on the front side.

- Pass the media between the light-shielding cover and the media guide and pull it out.

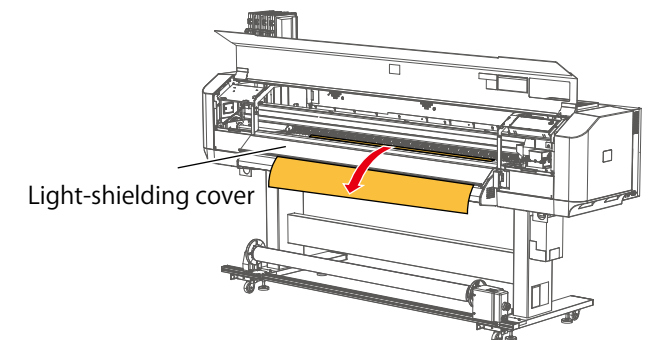

Before Use

Printing workflow

Basic Operations

Power on/off

Various settings

Load the media into the printer

Maintenance

Using the Take-up unit with the printer

When problems occur

Nozzle check and head cleaning

Appendix

Calibrating your printer

Start printing

Advanced settings

Operating from the printer control panel

- 6 While holding the media tip, rotate the flange of the roll media holder to slightly rewind the media to remove deflection and skew of the media.

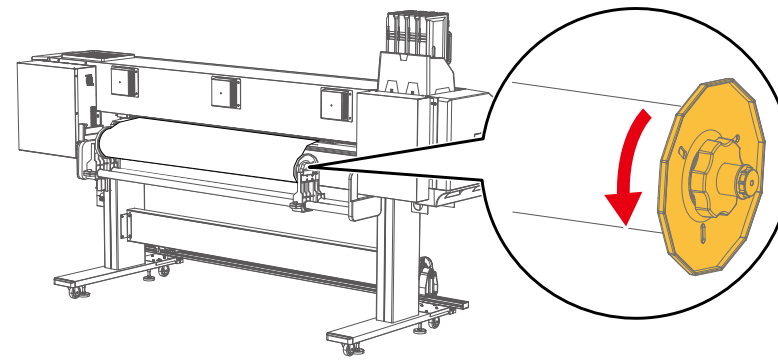

Note

If you release your hand while rewinding the media, the media may come loose from the media feed slot and fall to the rear side of the printer.

- 7 Make sure that the right edge of the media is not to the right of the media set guide line.
 - If media is located to the right of the media set guide, print quality may be affected.

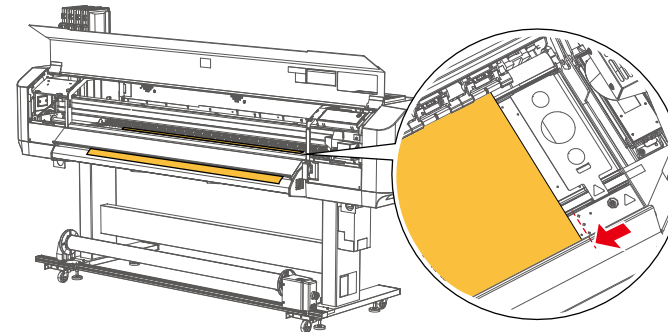

- 8 If necessary, change the pressurizing pressure of the pressure rollers individually.
 - ["Canceling or reducing pressure rollers individually" P.76](#)

Before Use

Printing workflow

Basic Operations

Power on/off

Various settings

Load the media into the printer

Maintenance

Using the Take-up unit with the printer

When problems occur

Nozzle check and head cleaning

Appendix

Calibrating your printer

Start printing

Advanced settings

Operating from the printer control panel

5. Procedure after media set

- 1 Push the media feed lever to the rear and lower the pressure rollers.

Note

The media feed lever can change the applied pressure to two levels: "Normal" and "High". In normal use, stop at the point where you feel a click on the front side and set the pressure to "Normal".

 ["Changing holddown pressure using media feed lever" P.75](#)

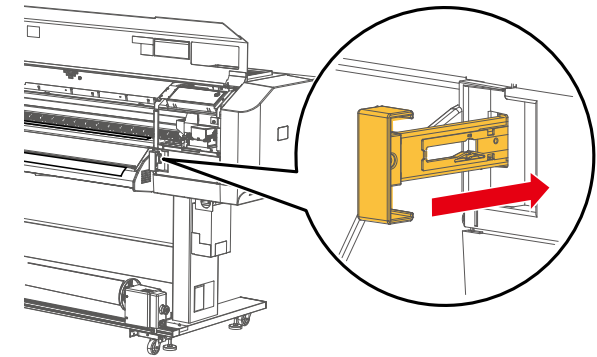

- 2 Make sure both ends of the media are held by the rollers of the pressure rollers.

- If the illustration applies to "bad", pull the media feed lever to the very front and then refer to ["3. Install media in the roll media holder" P.49](#) to change the position of the left and right roll media holders. (To be verified at both ends of the media)

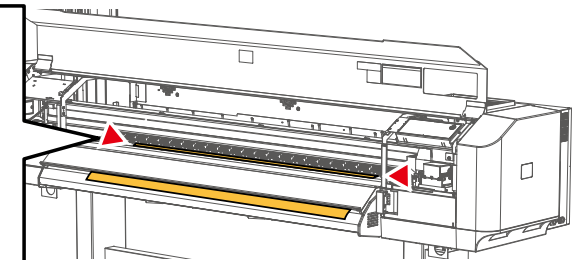
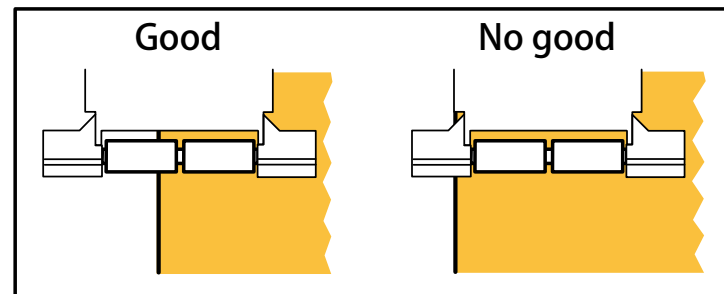

Before Use

Printing workflow

Basic Operations

Power on/off

Various settings

Load the media into the printer

Maintenance

Using the Take-up unit with the printer

When problems occur

Nozzle check and head cleaning

Appendix

Calibrating your printer

Start printing

Advanced settings

Operating from the printer control panel

3 Set edge holders on both ends of the media.

- Lifting the knob in front of the edge holder raises the center of the edge holder. While floating the center of the edge holder, move the edge holder to cover the edge of the media.

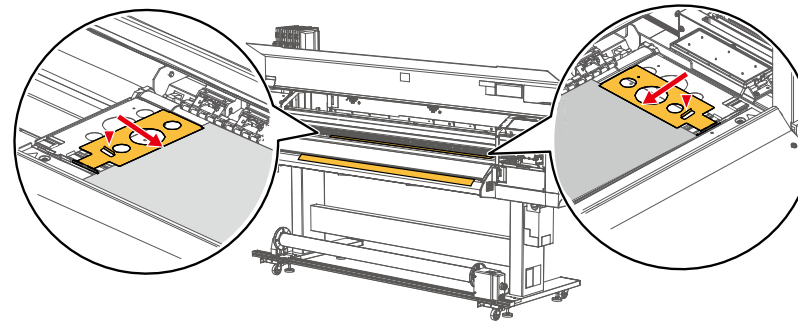

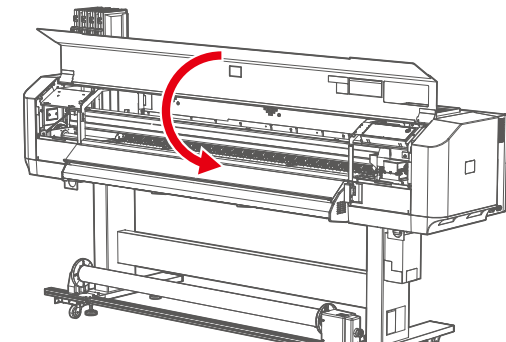

4 Close the front cover.



5 Tap ([Home] key).

6 "User: Type ** OK?" will be displayed.

- Select the User Type to be used with the  /  keys.
- Tap  ([Enter] key) to perform a media initial.
- Exit the Media Set.

Before Use

Printing workflow

Basic Operations

Power on/off

Various settings

Load the media into the printer

Maintenance

Using the Take-up unit with the printer

When problems occur

Nozzle check and head cleaning

Appendix

Calibrating your printer

Start printing

Advanced settings

Operating from the printer control panel

Using the Take-up unit with the printer

To wind up the media, follow these steps to load the media into the take-up unit.

1 Using the printer control panel, make necessary setting(s) to use the take-up unit.
☞ "Menu 1: Setup menus" P.89 > "Output Mode" P.92

2

- Fully pull the media feed lever towards you and raise the pressure rollers.
- Pull out the paper until its leading edge reaches the paper core.

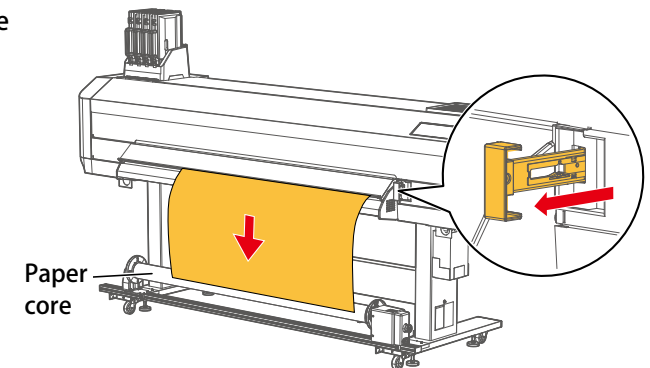

3

- Loosen the two thumbscrews on the take-up unit and adjust the paper core by shifting it left or right so that the right end of the paper core is aligned with the right end of the media.
- After adjustment, tighten the thumbscrews.

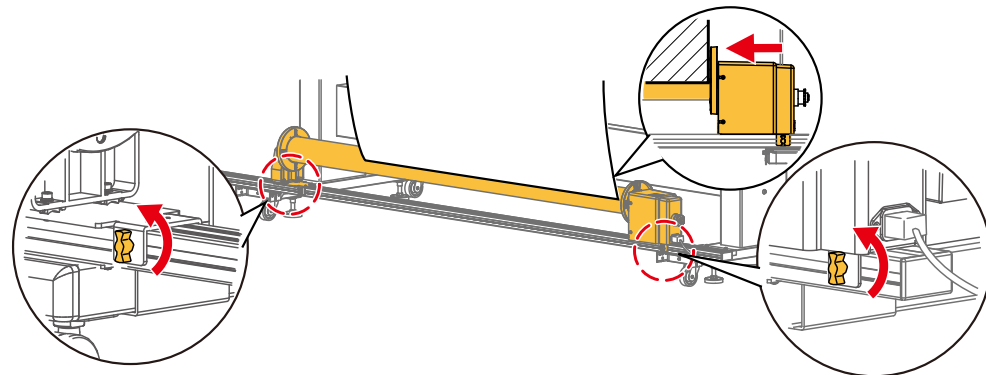

Before Use

Printing workflow

Basic Operations

Power on/off

Various settings

Load the media into the printer

Maintenance

Using the Take-up unit with the printer

When problems occur

Nozzle check and head cleaning

Appendix

Calibrating your printer

Start printing

Advanced settings

Operating from the printer control panel

4 Tape the leading edge of the media to the paper core of the take-up unit.

- Ensure that the leading edge of the media is parallel to the paper core. If they are not parallel, follow the procedure of step 5 through 7 to adjust it.

Note

This illustration shows when winding media with printed side facing out.

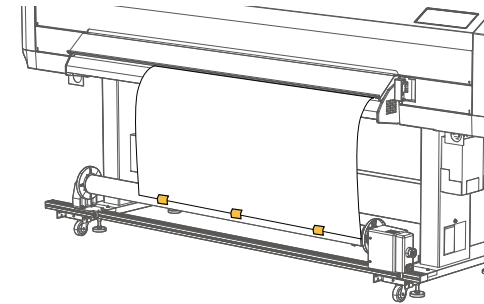

5 Using the supplied hex wrench, gently loosen the eight hex screws securing the rail holder.

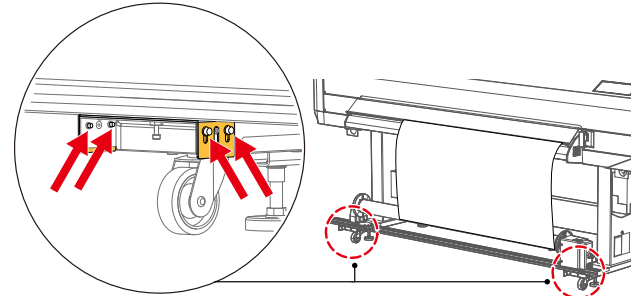

6 Adjust the height of both ends of the rail. Turn one hex screw on the underside of the rail base with the supplied hex wrench so that the leading edge of the media is parallel to the paper core.

- To raise height: Turn the screw counterclockwise
- To lower height: Turn the screw clockwise

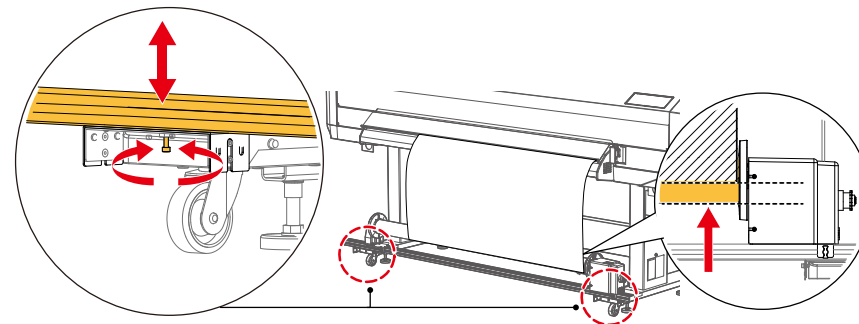

Before Use

Printing workflow

Basic Operations

Power on/off

Various settings

Load the media into the printer

Maintenance

Using the Take-up unit with the printer

When problems occur

Nozzle check and head cleaning

Appendix

Calibrating your printer

Start printing

Advanced settings

Operating from the printer control panel

- 7 Tighten the eight hex screws securing the rail holder firmly.

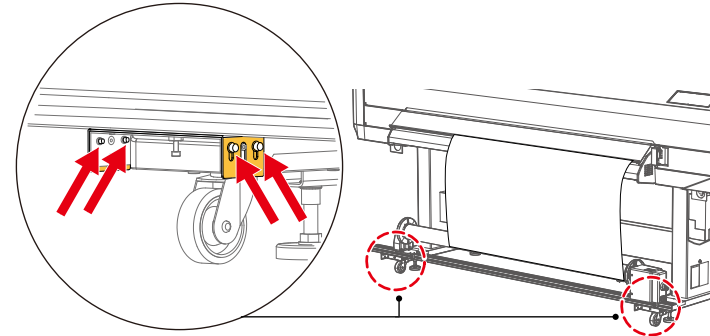

- 8 Turn the operation switch to A or C and wind the media for about two rounds.

- A: Wind media counterclockwise (printed side facing out).
- B: Stop
- C: Wind media clockwise (printed side facing in).

Note

- Operation switch turns green during operation.
- Make sure that the operation switch is turned on (to wind) while printing.

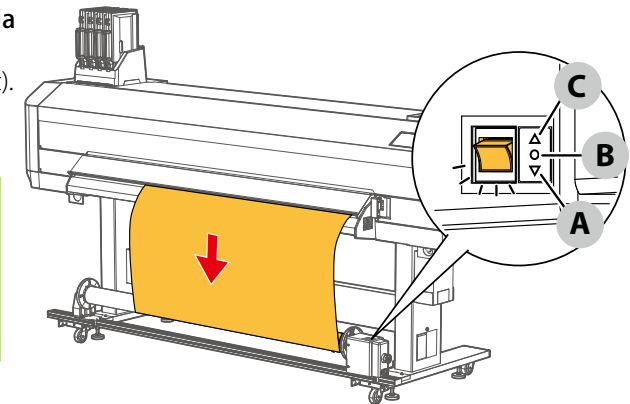

- 9 Push the media feed lever all the way in and lower the pressure rollers.

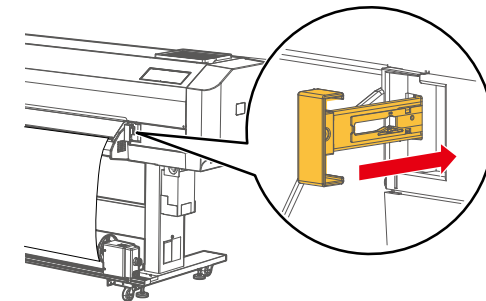

Before Use

Printing workflow

Basic Operations

Power on/off

Various settings

Load the media into the printer

Maintenance

Using the Take-up unit with the printer

When problems occur

Nozzle check and head cleaning

Appendix

Calibrating your printer

Start printing

Advanced settings

Operating from the printer control panel

10

To change the winding force, adjust the torque adjustment screw.

- Clockwise: Increase the winding force
- Counterclockwise: Decrease the winding force

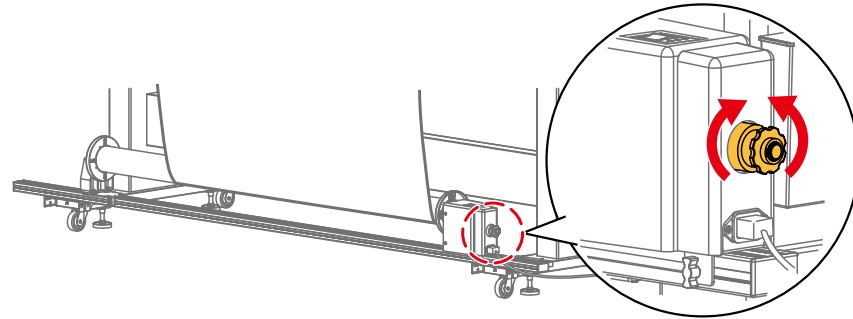

Note

Adjust it when the media is loose on the paper core or the take-up unit is not winding correctly.

Before Use

Printing workflow

Basic Operations

Power on/off

Various settings

Load the media into the printer

Maintenance

Using the Take-up unit with the printer

When problems occur

Nozzle check and head cleaning

Appendix

Calibrating your printer

Start printing

Advanced settings

Operating from the printer control panel

Nozzle check and head cleaning

Check nozzles before each day's work. If the nozzle is clogged, perform head cleaning.

Performing Nozzle Check





Run a nozzle check print to see if the print head fires ink properly.

- 1 Load media and detect media width.
👉 "Load the media into the printer" P.45

- 2 Tap  key while "Print Ready" is displayed.
 - The "Nozzle Check F Start" -> Enter" will appear.

Note

The following steps can also be performed

1. Tap  ([Home] key). "Setup" will be displayed.
2. Tap  /  key to display "Test Print".
3. Tap  key to display "Nozzle Check F".

- 3 Tap  ([Enter] key).
 - Prints a nozzle check pattern.

Before Use

Printing workflow

Basic Operations

Power on/off

Various settings

Load the media into the printer

Maintenance

Using the Take-up unit with the printer

When problems occur

Nozzle check and head cleaning

Appendix

Calibrating your printer

Start printing

Advanced settings

Operating from the printer control panel

4 Check the pattern.

If the nozzle is clogged, go to "[Performing Head cleaning](#)" P.63.

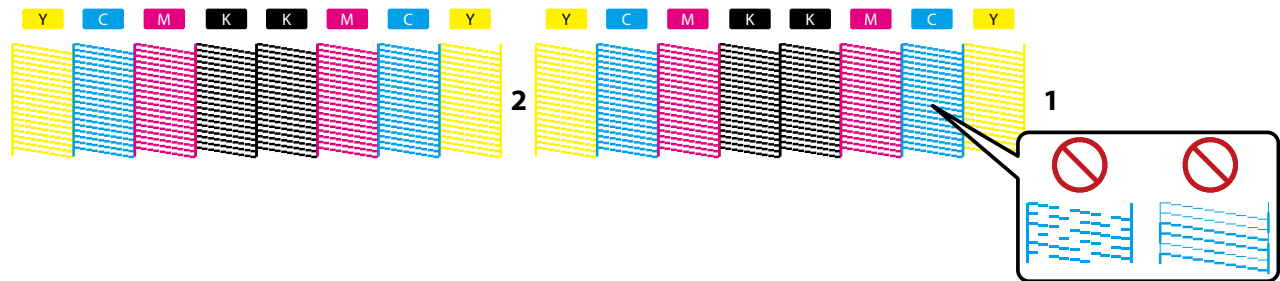

Note

Printer information (print time, serial number, and firmware version) is printed.

Important!

If a nozzle check is performed immediately after the Initial Charge is completed, the following phenomenon may occur

- Printed lines are blurred
- Not partially printed

In such cases, perform Little Charge of "[Nozzle check and head cleaning](#)" P.152. If there is no change in the nozzle check pattern after performing Little Charge, leave the printer for at least one hour and perform cleaning or Little Charge.

Before Use	Printing workflow
Basic Operations	Power on/off
Various settings	Load the media into the printer
Maintenance	Using the Take-up unit with the printer
When problems occur	Nozzle check and head cleaning
Appendix	Calibrating your printer
	Start printing
	Advanced settings
	Operating from the printer control panel

Performing Head cleaning

If the nozzle is clogged, perform a head cleaning. The product has several cleaning modes. Use it according to the print results of the nozzle check.

■ Head cleaning mode

Short Cleaning	Consumes a small amount of ink.
Normal cleaning	Select this mode if there are nozzle clogging.
Long cleaning	Select this mode if nozzle clogging persists even if "Normal cleaning" was performed.
Little Charge * Cleaning menu only	Gives high cleaning efficiency, but consumes large amount of ink. 👉 "Menu 3: Cleaning" P.111
Initial Charge * Cleaning menu only	Offers more powerful cleaning than "Little Charge", but consume large amount of ink. 👉 "Menu 3: Cleaning" P.111

📢 Important!!

When performing "Little Charge" and "Initial Charge", observe the following. A large amount of ink is consumed to re-fill the ink.







- Do not turn off the power.
- Do not unplug the power cable.
- Do not open the front cover or maintenance cover.
- Do not raise the pressure rollers.
- Do not pull out the ink bag case or smart chip card.
- Do not use ink bags with low ink levels.



Before Use	Printing workflow
Basic Operations	Power on/off
Various settings	Load the media into the printer
Maintenance	Using the Take-up unit with the printer
When problems occur	Nozzle check and head cleaning
Appendix	Calibrating your printer
	Start printing
	Advanced settings
	Operating from the printer control panel

- 1** Tap  key.
 - "Clean Print Head?" is displayed.

 **Note**

The following procedure allows you to select the head (All / Head1 / Head2) to be cleaned.

1. Tap  ([Home] key). "Setup" will be displayed.
2. Tap  /  key to display "Cleaning".
3. Tap  key to display "Head Select:".
4. Tap  /  key to select the head to be cleaned.





- 2** Tap  /  key to select the cleaning mode.
 - For more information on cleaning modes, see "[Head cleaning mode](#)" P.63.

- 3** Tap  ([Enter] key).
 - Cleaning is started.

- 4** Print a nozzle check to see if the nozzles are clogged.
 -  "[Performing Nozzle Check](#)" P.61
 - If the nozzle clogging is not corrected, repeat the Normal cleaning process.

 **Note**

If nozzle clogging persists after repeated Normal cleaning attempts, try the following solutions for a reference.

1. Perform a Long cleaning. (If the problem persists, move to the next one)
2. Clean the following parts. (If the problem persists, move to the next one)
 -  "[4. Clean the cleaning wiper and the parts around the capping unit](#)" P.147
 -  "[3. Clean the parts around the print head](#)" P.146
3. Perform a Little Charge cleaning. (If the problem still persists, move to the next one)
 -  "[Menu 3: Cleaning](#)" P.111
4. Perform a soak cleaning.
 -  "[Menu 12: Soak Cleaning](#)" P.125

Before Use	Printing workflow
Basic Operations	Power on/off
Various settings	Load the media into the printer
Maintenance	Using the Take-up unit with the printer
When problems occur	Nozzle check and head cleaning
Appendix	Calibrating your printer
	Start printing
	Advanced settings
	Operating from the printer control panel

Calibrating your printer

The following calibration must be performed before you print for the first time.

- **"Adjust Head" P.108**
This product is equipped with two printheads. This adjustment will calibrate dot placement between two print heads. After performing "Adjust Head", you must perform print quality calibration ("Adjust Print").
- **"Print quality calibration (Adjust Print)" P.97**
This calibration will adjust the dot placement in bidirectional printing. You will enter the thickness of media before adjustment.
- **"Media feed adjustment" P.102**
This adjustment will correct the media feed amount.

Before Use

Printing workflow

Basic Operations

Power on/off

Various settings

Load the media into the printer

Maintenance

Using the Take-up unit with the printer

When problems occur

Nozzle check and head cleaning

Appendix

Calibrating your printer

Start printing

Advanced settings

Operating from the printer control panel

Start printing

This section describes the basic printing procedure using VerteLith.
Please refer to the separate "VerteLith User Manual" for VerteLith setup and detailed operating instructions.

- 1 Start VerteLith. Select "HA-1642" from the list of printer (①).
 - [HA-1642] will appear (②).

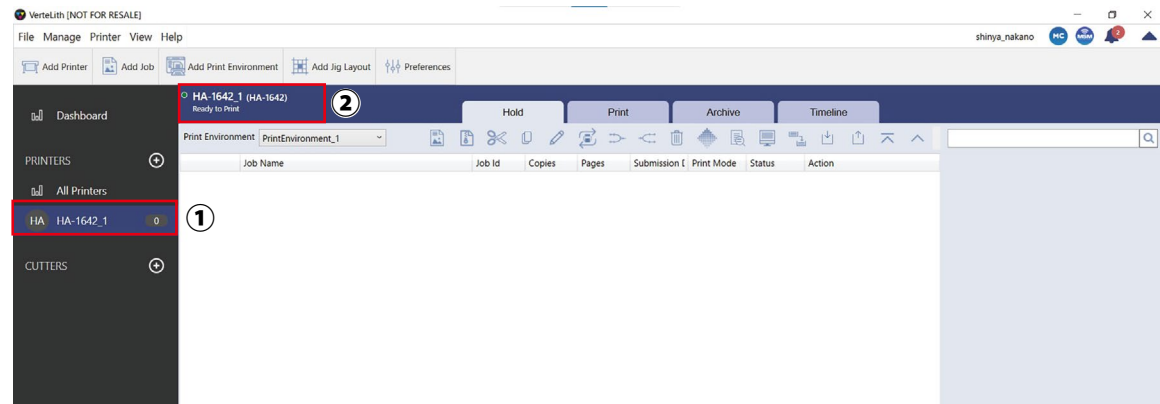

Note

For how to add a printer to VerteLith, see the VerteLith user manual.

Before Use

Printing workflow

Basic Operations

Power on/off

Various settings

Load the media into the printer

Maintenance

Using the Take-up unit with the printer

When problems occur

Nozzle check and head cleaning

Appendix

Calibrating your printer

Start printing

Advanced settings

Operating from the printer control panel

2 Add an image file you want to print.

- In the Hold queue, click the [Add Job] icon (③) so that the open dialog appears.

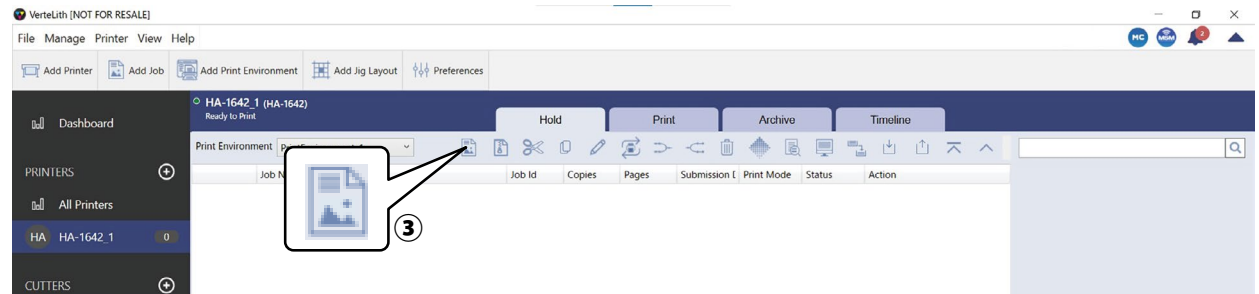

- Select an image file and click [OK] to add it to the Hold queue (④). You can add multiple files here.

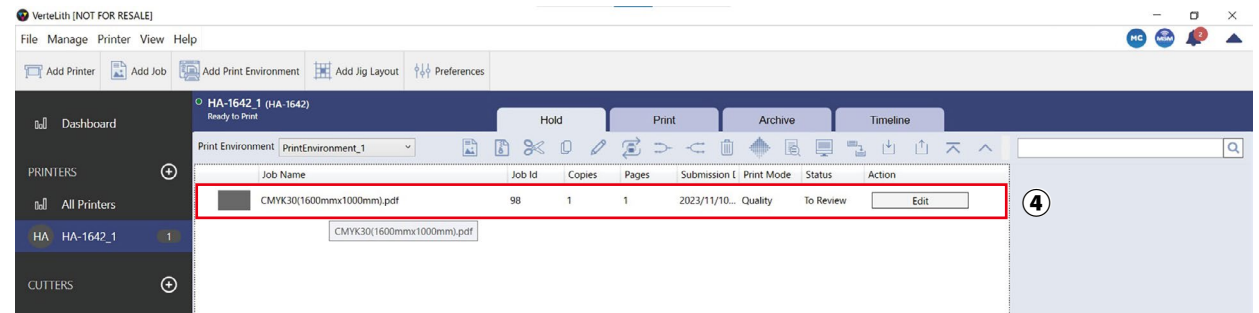

Note

You can also drag and drop files in the Hold queue.

Before Use

Printing workflow

Basic Operations

Power on/off

Various settings

Load the media into the printer

Maintenance

Using the Take-up unit with the printer

When problems occur

Nozzle check and head cleaning

Appendix

Calibrating your printer

Start printing

Advanced settings

Operating from the printer control panel

3 Select a print job and click [Edit](⑤) or [Edit Job](⑥).

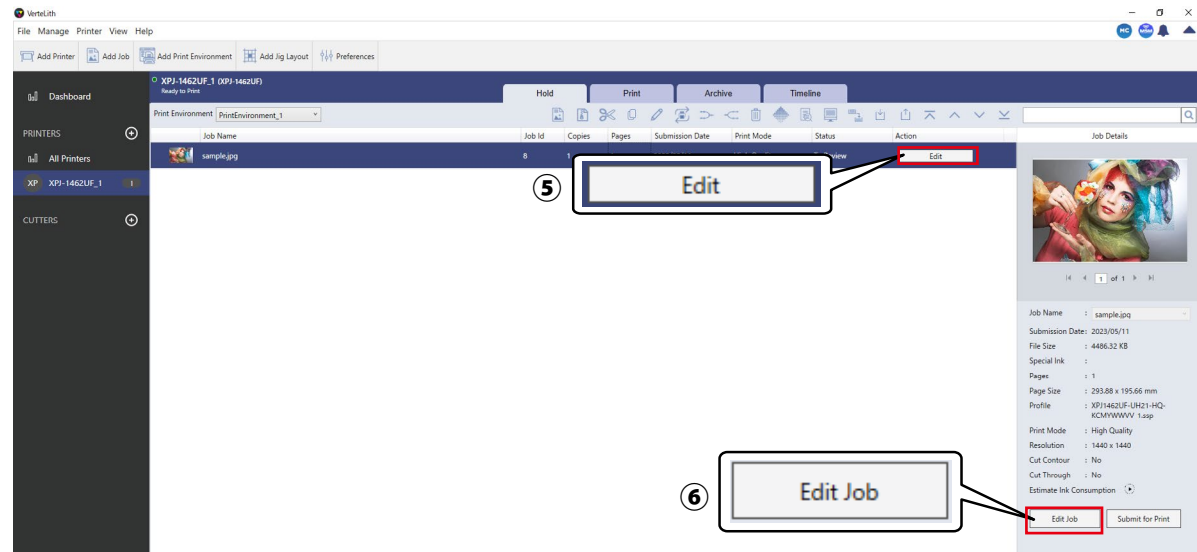

4 [Edit Job Settings](⑦) appears. Click the Printer Profile tab (⑧).

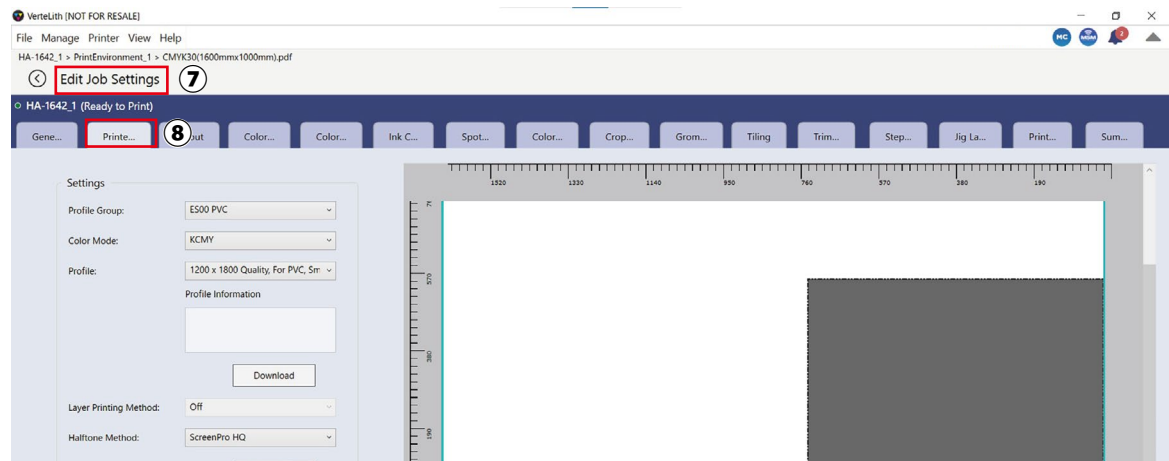

Before Use

Printing workflow

Basic Operations

Power on/off

Various settings

Load the media into the printer

Maintenance

Using the Take-up unit with the printer

When problems occur

Nozzle check and head cleaning

Appendix

Calibrating your printer

Start printing

Advanced settings

Operating from the printer control panel

5 Configure the basic print settings.

Profile Group option (9)

- Select an appropriate profile group depending on the ink being used.

Profile option (10)

- Select an appropriate profile depending on the media type and print mode.

Printer Options (11)

- Additional advanced settings can be configured (you can also print with default settings).

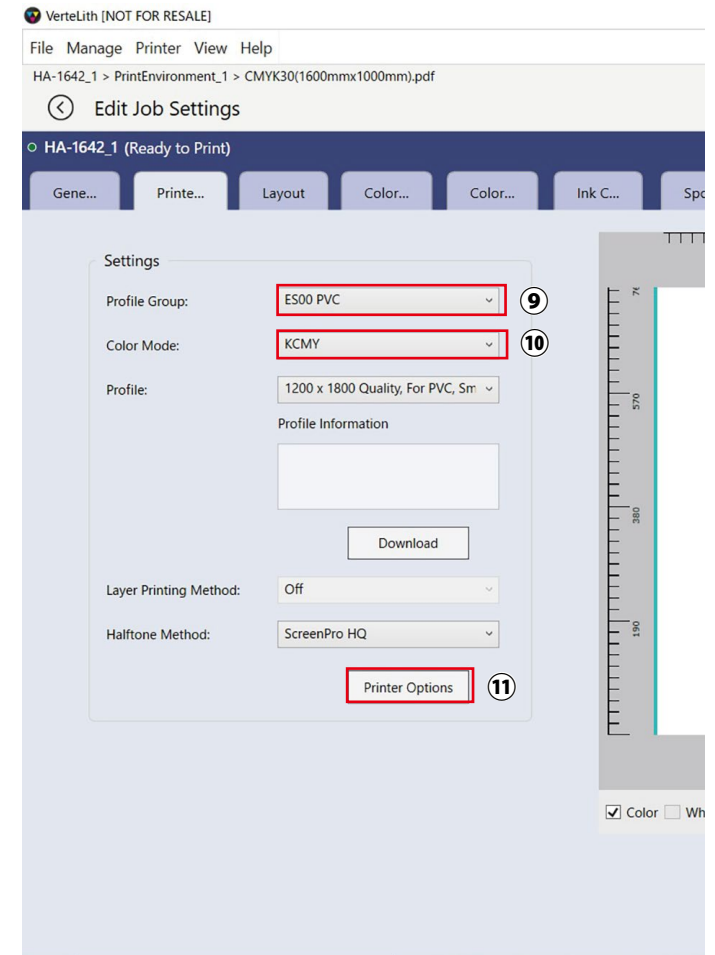

Before Use

Printing workflow

Basic Operations

Power on/off

Various settings

Load the media into the printer

Maintenance

Using the Take-up unit with the printer

When problems occur

Nozzle check and head cleaning

Appendix

Calibrating your printer

Start printing

Advanced settings

Operating from the printer control panel

6 Once you have set the print settings, click [Submit for Print] (12) so that the job will move to the Print queue. Printing begins after RIP processing.

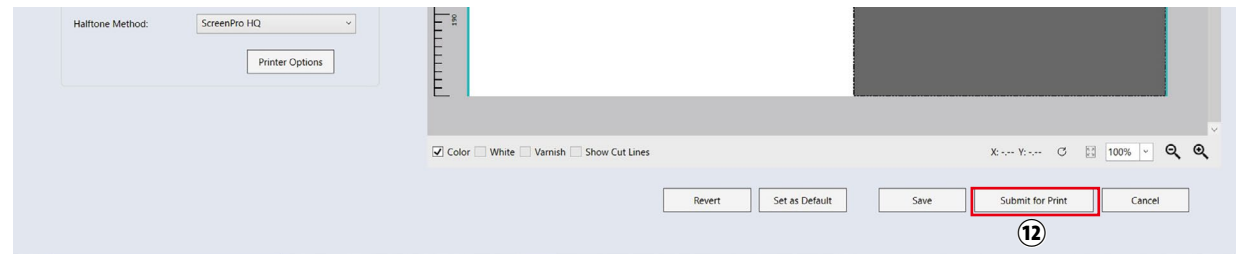

• The processing status of the job (Sending, Waiting for ripping, Ripping, Waiting for Print) can be viewed (13).

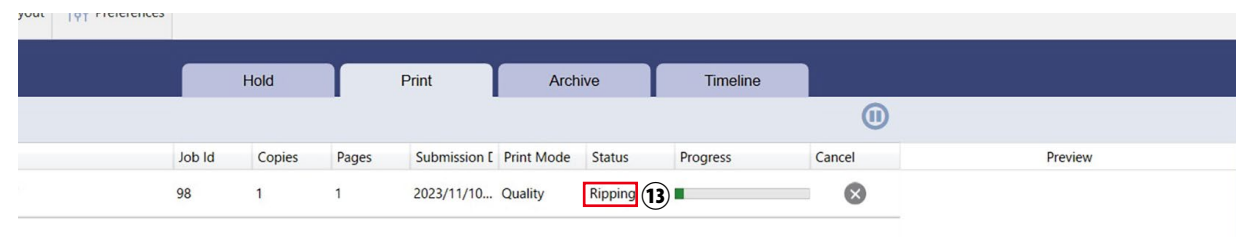

• The job will automatically move to the Hold queue after printing (14).

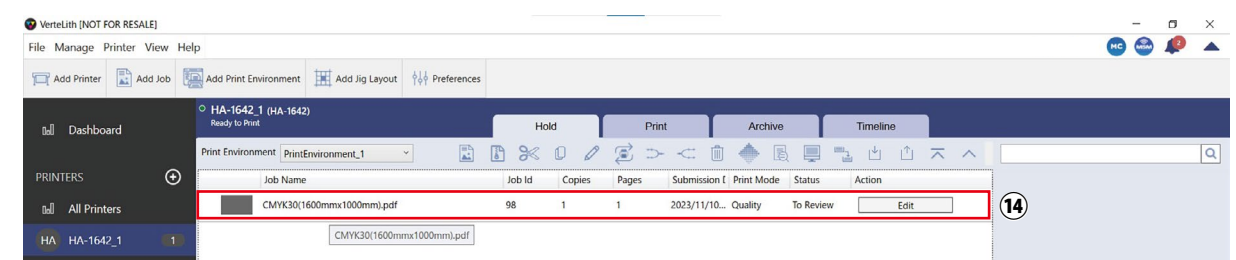

Before Use

Printing workflow

Basic Operations

Power on/off

Various settings

Load the media into the printer

Maintenance

Using the Take-up unit with the printer

When problems occur

Nozzle check and head cleaning

Appendix

Calibrating your printer

Start printing

Advanced settings

Operating from the printer control panel

Pause / Resume / Cancel a print job

- 1 Clicking the [Pause Print] icon (①) will put the RIP processed job into “Waiting for Print” status (you cannot pause the job being sent).

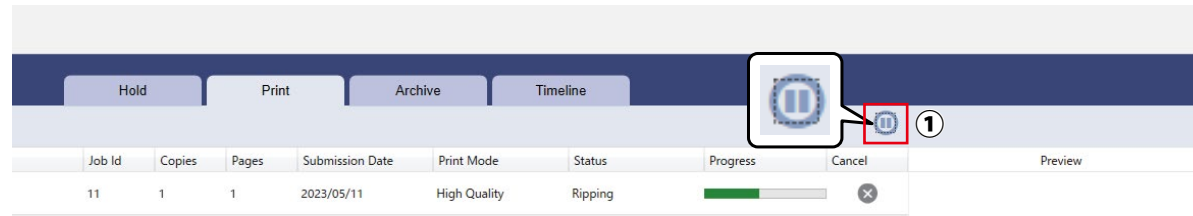

- 2 Clicking the [Resume Print] icon (②) will resume the print job which is in “Wait for Print” status.

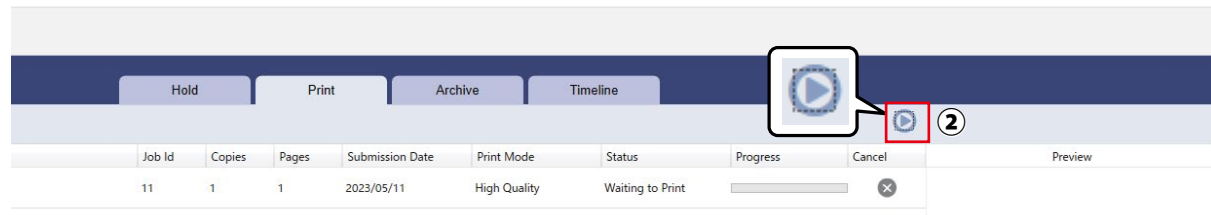

- 3 Clicking the [Cancel] icon (③) will cancel printing the job.

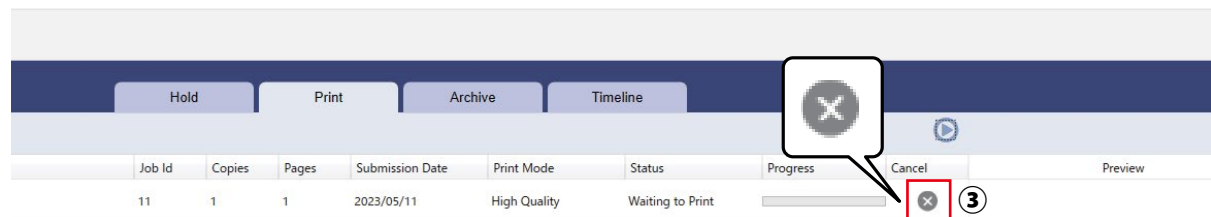

Before Use	Printing workflow
Basic Operations	Power on/off
Various settings	Load the media into the printer
Maintenance	Using the Take-up unit with the printer
When problems occur	Nozzle check and head cleaning
Appendix	Calibrating your printer
	Start printing
	Advanced settings
	Operating from the printer control panel

Advanced settings

Change the printer settings depending on the media being used and how it is used.

- When the media rubs against the print head and gets dirty
 - ☞ ["Print head Height" P.73](#)
- When printing on thin or soft media
 - ☞ ["Changing holddown pressure using media feed lever" P.75](#)
 - ☞ ["Canceling or reducing pressure rollers individually" P.76](#)

 **Note**

When printing on thin or soft media, reducing the vacuum fan is also helps to prevent wrinkling.

☞ ["Vacuum Fan" P.90](#)

Before Use	Printing workflow
Basic Operations	Power on/off
Various settings	Load the media into the printer
Maintenance	Using the Take-up unit with the printer
When problems occur	Nozzle check and head cleaning
Appendix	Calibrating your printer
	Start printing
	Advanced settings
	Operating from the printer control panel

Print head Height

Normally choose the "Low" or "Middle" head height option depending on media thickness. The closer the distance between the media and the print head, the better the consistency of the image quality.

Important!!

Depending on the condition of the media and wrinkling caused by printing conditions, you may get a head strike causing ink smears on the media. In such cases, try the following

- Lower the preheater and platen heater temperature settings
 ➔ "Menu 1: Setup menus" P.89 > "User Type" P.89 > "Preheater"90 Page,"Platen Heater" P.90
- Reduce/cancel the pressure on the individual pressure rollers holding down the area where the wrinkle occurred.
 ➔ "Canceling or reducing pressure rollers individually" P.76
- After you change the head height, make sure to perform the print quality calibration (Adjust Print).
- Do not open the front cover to switch head height during printing. Switching the head height will change the "Print quality calibration (Adjust Print)" and print quality cannot be guaranteed.

See the following table for the relationship between head height and recommended media thickness. Avoid using higher head height unless absolutely necessary, as the wider head gap will cause ink mist to adhere to the nozzles, media, and inside the machine, which may result in poor print quality and damage to printer parts

Head height	Recommended media thickness (1.0 mm or less)	Maximum media thickness that printer can feed	Description.
Low	Max. 0.3 mm	0.3 mm	Normally use this head height.
Middle	0.3 mm to 0.8 mm	0.8 mm	Use this option for media between 0.3 mm to 0.8 mm thick or when the head strikes occur with Low setting.
High	0.8 mm to 1.3 mm	1.3 mm	Avoid using this option if a head strike does not occur with Middle setting. Because of wide distance between the print head and media, printing with "High" setting will generate ink mist, <ul style="list-style-type: none"> • Nozzle clogging • Ink smudges due to ink mist • Ink sticking inside of the printer

Before Use

Printing workflow

Basic Operations

Power on/off

Various settings

Load the media into the printer

Maintenance

Using the Take-up unit with the printer

When problems occur

Nozzle check and head cleaning

Appendix

Calibrating your printer

Start printing

Advanced settings

Operating from the printer control panel

Change head height

1 Open the front cover.

2 Use this lever to change the head height.

Head height	Description.
High	The highest head height setting.
Middle	Use this option for media between 0.3 mm to 0.8 mm thick or when the head strikes occur with Low setting.
Low	Default head height. The lowest head height setting.

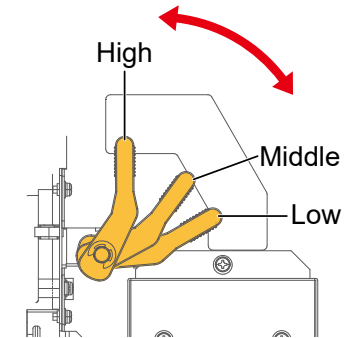

3 Close the front cover.

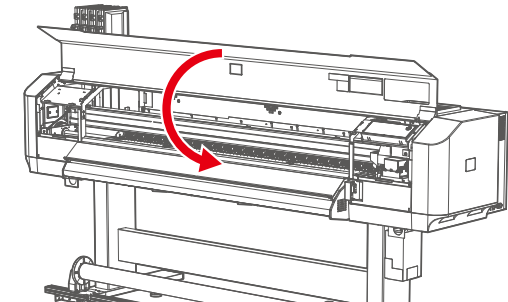

4 Perform "Print quality calibration (Adjust Print)".
👉 ["Print quality calibration \(Adjust Print\)" P.97](#)

Before Use

Printing workflow

Basic Operations

Power on/off

Various settings

Load the media into the printer

Maintenance

Using the Take-up unit with the printer

When problems occur

Nozzle check and head cleaning

Appendix

Calibrating your printer

Start printing

Advanced settings

Operating from the printer control panel

Changing holddown pressure using media feed lever

If you want to change the holddown pressure applied across the entire width of media, change it using the media feed lever.

Depending on the position of the lever, you can choose the pressure between Normal and High.

- Normal: Recommended for typical roll media. To apply normal pressure, push the lever from the front side of the printer until it clicks.
- High: Recommended for heavy weight media (such as Tarpaulin). To apply high pressure, push it as far as it goes.

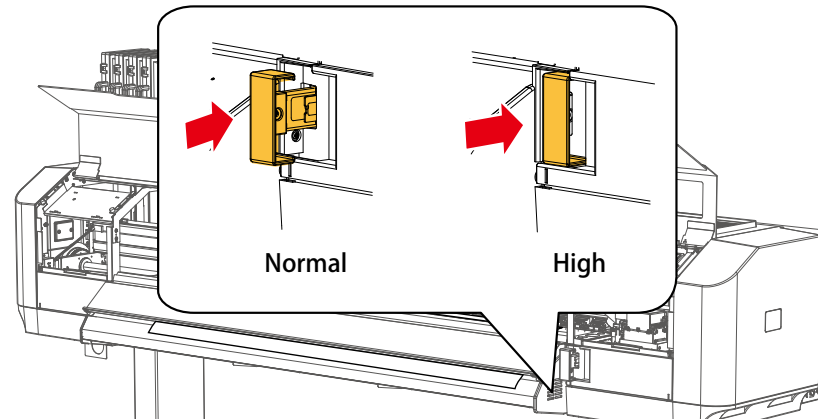

Important!!

Every time after you change the holddown pressure by the media feed lever, you must perform the media feed adjustment.

 ["Media feed adjustment" P.102](#)

Before Use	Printing workflow
Basic Operations	Power on/off
Various settings	Load the media into the printer
Maintenance	Using the Take-up unit with the printer
When problems occur	Nozzle check and head cleaning
Appendix	Calibrating your printer
	Start printing
	Advanced settings
	Operating from the printer control panel

Canceling or reducing pressure rollers individually

When printing on thin or soft media, sometimes the media hits the print head causing ink smudge on the media. By reducing pressure or disabling the pressure rollers individually, it helps to reduce the chance of head strike. The slide lock lever on each pressure rollers can be used to change the pressure to "Normal," "Low," or "Cancel" .

- Normal: Recommended for typical roll media. The factory default is set to Normal.
- Low: It reduces the holddown pressure.
- Cancel: It disables the pressure roller.

When the media feed lever is set to "High", you can only choose between Normal and Cancel (even you set it to Low, the holddown pressure will not be reduced).

To set the slide lock lever to "Cancel", pull the media feed lever to the very front and perform it with the pressure rollers raised.

Media feed lever	Slide lock lever
Normal	Normal/Weak/Cancel
High	Normal/Cancel

Important!!

Every time after you change the holddown pressure by individual slide lock lever, you must perform the media feed adjustment.

["Media feed adjustment" P.102](#)

Note

Thin or stiff media tends to wrinkle easily during printing. Wrinkles can contact the bottom side of the print head causing ink smudge on the media. Canceling the pressure rollers on both edges of media will help prevent wrinkling.

- 1 Open the front cover.

Before Use

Printing workflow

Basic Operations

Power on/off

Various settings

Load the media into the printer

Maintenance

Using the Take-up unit with the printer

When problems occur

Nozzle check and head cleaning

Appendix

Calibrating your printer

Start printing

Advanced settings

Operating from the printer control panel

2 Change the position of the media feed lever according to the application.

- To set the slide lock lever to Cancel
 - Pull the media feed lever to the very front and raise the pressure rollers.
 - To set the slide lock lever to low
 - Set the media feed lever to the "Normal" set position.
- ☞ "Changing holddown pressure using media feed lever" P.75

Note

The slide lock lever cannot be set to "Cancel" unless the media feed lever is pulled to the very front.

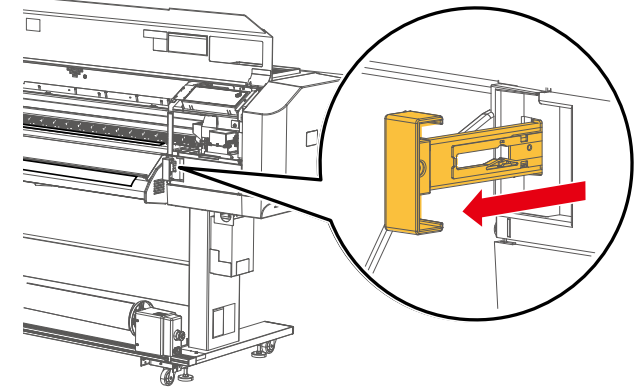

3 Push down the tab on the slider lock lever, then slide it to the front.

- To reduce pressure, slide it to front until it clicks.
- To cancel the pressure roller, fully slide it to the front until it clicks into place.

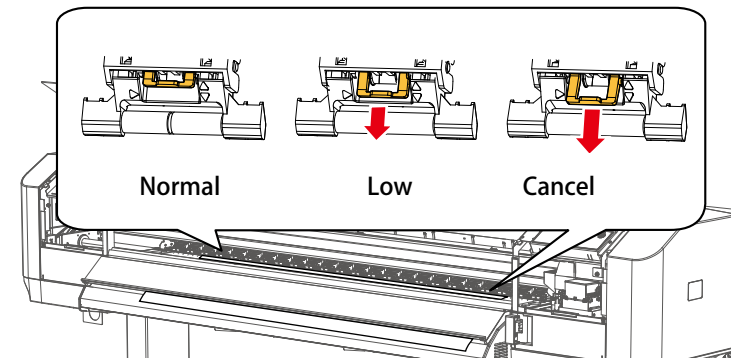

Note

First, try with the pressure rollers holding both ends of the media, and if the problem persists, reduce or cancel more rollers.

Before Use

Printing workflow

Basic Operations

Power on/off

Various settings

Load the media into the printer

Maintenance

Using the Take-up unit with the printer

When problems occur

Nozzle check and head cleaning

Appendix

Calibrating your printer

Start printing

Advanced settings

Operating from the printer control panel

- 4 (To cancel the individual pressure rollers) Push the media feed lever back to its original position and lower the pressure rollers.

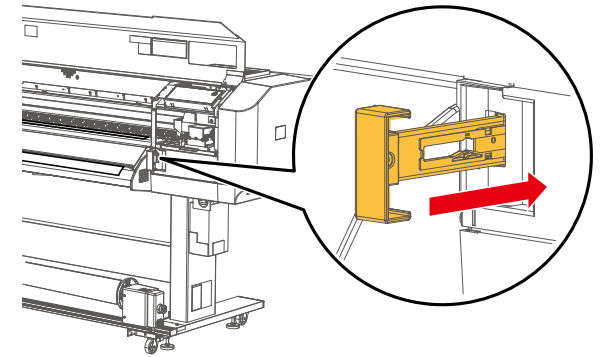

- 5 Close the front cover.

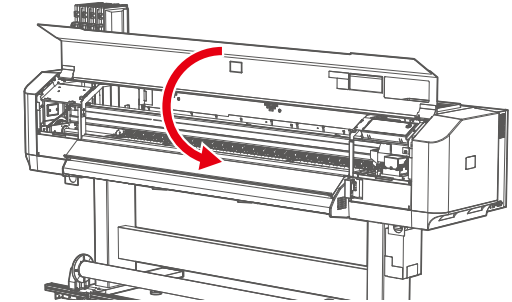

- 6 Perform media feed adjustment
☞ "Media feed adjustment" P.102

Before Use

Printing workflow

Basic Operations

Power on/off

Various settings

Load the media into the printer

Maintenance

Using the Take-up unit with the printer

When problems occur

Nozzle check and head cleaning

Appendix

Calibrating your printer

Start printing

Advanced settings



Operating from the printer control panel

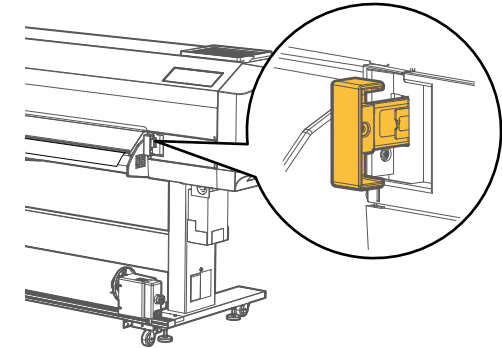

Operating from the printer control panel

Feeding media

1 Ensure that the pressure rollers is lowered.



2 Tap  or  key.

-  Key: Feed the media backward.
-  Key: Feed the media forward.

 **Note**

Long touch the key to feed the media with high speed.

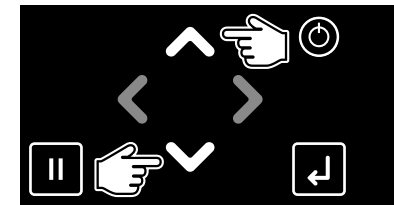

3 Once it has reached the intended position, release the key.

Before Use	Printing workflow
Basic Operations	Power on/off
Various settings	Load the media into the printer
Maintenance	Using the Take-up unit with the printer
When problems occur	Nozzle check and head cleaning
Appendix	Calibrating your printer
	Start printing
	Advanced settings
	Operating from the printer control panel

Pause / Resume printing

- 1 While printing, tap  ([Cancel] key).
 - Printing pauses.

Note
 This operation does not delete the print data sent to the printer. To cancel printing and delete data, see the following section.
 ➔ ["Cancel printing" P.81](#)

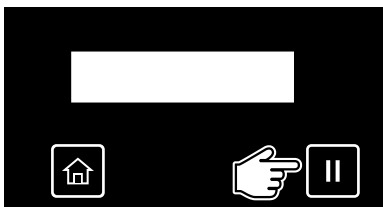

- 2 Tap  ([Cancel] key) again to resume printing.

Important!!
 Print quality cannot be guaranteed if printing is paused.



Before Use

Printing workflow

Basic Operations

Power on/off

Various settings

Load the media into the printer

Maintenance

Using the Take-up unit with the printer

When problems occur

Nozzle check and head cleaning

Appendix

Calibrating your printer

Start printing

Advanced settings

Operating from the printer control panel

Cancel printing

- 1 While printing, tap  ([Cancel] key).
 - Printing pauses.

Note

To resume printing, tap Cancel key again.



- 2 Tap  ([Enter] key) to cancel printing (Once canceled, you cannot resume the job again.)
 - Print data sent to the printer is deleted.

Note

You can also cancel the job from the remote panel on MSM.

Pausing Print

Cancel Print

-> Enter

Before Use	Printing workflow
Basic Operations	Power on/off
Various settings	Load the media into the printer
Maintenance	Using the Take-up unit with the printer
When problems occur	Nozzle check and head cleaning
Appendix	Calibrating your printer
	Start printing
	Advanced settings
	Operating from the printer control panel

Start printing during warm-up

1 Check that the printer is warming up.



2 Send a print data.
 • Use or key to select "Yes".

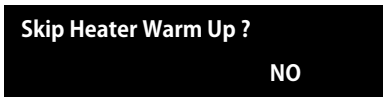

3 Tap ([Enter] key) to start printing.

Important!!
 Print quality cannot be guaranteed if printing is started during warm-up.

Note
 If printing is started during warm-up, warm-up continues to the set temperature.

Caution
 Do not touch the media guide while printing or when the message "Warming Up" appears on the panel. There is a risk of burn injuries.

Before Use	Printing workflow
Basic Operations	Power on/off
Various settings	Load the media into the printer
Maintenance	Using the Take-up unit with the printer
When problems occur	Nozzle check and head cleaning
Appendix	Calibrating your printer
	Start printing
	Advanced settings
	Operating from the printer control panel

Cutting Media

- 1 Ensure that printing is finished.
 - Tap  ([Cancel] key).



- 2 Tap  ([Enter] key).
 - The printer will advance the media for the bottom margin and will cut it off the roll media.



Note



- If the leading edge of a new roll media is not straight, cut it before printing.
- When Media Initial menu is set to "Off", the printer does not cut the media automatically.
 - 👉 ["Menu 1: Setup menus" P.89](#) > ["User Type" P.89](#) > 👉 ["Media Initial" P.92](#)
- When the Output Mode menu is set to "Auto Cut", the printer cuts the media automatically after printing.
 - 👉 ["Menu 1: Setup menus" P.89](#) > ["User Type" P.89](#) > 👉 ["Output Mode" P.92](#)
- The cutter blade is consumable parts. Replace it when needed.
 - 👉 ["Replace the Cutter" P.163](#)









Before Use	Printing workflow
Basic Operations	Power on/off
Various settings	Load the media into the printer
Maintenance	Using the Take-up unit with the printer
When problems occur	Nozzle check and head cleaning
Appendix	Calibrating your printer
	Start printing
	Advanced settings
	Operating from the printer control panel

Menus you can access while printing

1 Tap  (the [Home] key) when one of the messages on the right is displayed.

Receiving	PG: Low	W: 1625 mm
Printing	PG: Low	W: 1625 mm
Converting	PG: Low	W: 1625 mm

2 Use  or  key to select the menu, then tap the  key.

Item	Description
Temperature	<p>Check heater temperature. The current temperature and the specified temperature are displayed in [].</p> <ul style="list-style-type: none"> Use  /  key to select the item you want to view. <div style="border: 1px solid green; padding: 5px; margin-top: 10px;"> <p> Note</p> <ul style="list-style-type: none"> The temperatures displayed are for reference only. Exact accuracy is not guaranteed. The current temperature blinks constantly regardless of whether the warm-up is completed or not. </div>
Preheater Platen heater Dryer	<p>Change heater temperature.</p> <ul style="list-style-type: none"> Use  /  key to change the temperature setting, then tap  ([Enter] key). <div style="border: 1px solid green; padding: 5px; margin-top: 10px;"> <p> Note</p> <ul style="list-style-type: none"> The change made will become invalid after printing. You can also save this change in the selected user type. <p> "Backup" P.85</p> </div>

Before Use	Printing workflow
Basic Operations	Power on/off
Various settings	Load the media into the printer
Maintenance	Using the Take-up unit with the printer
When problems occur	Nozzle check and head cleaning
Appendix	Calibrating your printer
	Start printing
	Advanced settings
	Operating from the printer control panel

Item	Description
PF Micro Adjust	<p>Correct the media feed amount.</p> <ul style="list-style-type: none"> Use / key to change the settings, then tap ([Enter] key). <div style="border: 1px solid #92d050; padding: 5px; margin-top: 10px;"> <p> Note</p> <ul style="list-style-type: none"> The change made will become invalid after printing. You can also save this change in the selected user type. <p> "Backup" P.85</p> </div>
Backup	<p>Save the change made in the following menus to the selected user type.</p> <ul style="list-style-type: none"> Preheater Platen Heater Dryer PF Micro Adjust <ul style="list-style-type: none"> Use / key to select "Yes" and tap ([Enter] key)
Job status	<p>Displays information about a print job being printed.</p> <ul style="list-style-type: none"> ToDoLength: Displays the length of print data. (media feed direction). Done: Displays the length printed. Print Remain: Displays the length of data which has not been printed yet. Remain Time: Displays the time remaining to finish printing. <ul style="list-style-type: none"> Use / key to select the item you want to view. <div style="border: 1px solid #92d050; padding: 5px; margin-top: 10px;"> <p> Note</p> <ul style="list-style-type: none"> The value displayed is reference only, not guaranteed. If print data does not contain length information, "0" is displayed for all items. </div>
MPS	Displays the status of the MPS function. MPS function settings can be changed from the MSM

Various settings

Key operation	87
Menu 1: Setup menus	89
Menu 2: Test Print	106
Menu 3: Cleaning	111
Menu 4: Menu Option	112
Menu 5: System Info.	113
Menu 6: Sleep mode	114
Menu 7: Initial Settings	115
Menu 8: Job status	116
Menu 9: Roll Length Manage	117
Menu 10: Media Adjustment	121
Menu 11: CR Maintenance	123

Before Use

Basic Operations

Various settings

Maintenance

When problems occur

Appendix

Key operation

Menu 1: Setup menus

Menu 2: Test Print

Menu 3: Cleaning

Menu 4: Menu Option

Menu 5: System Info.

Menu 6: Sleep mode

Menu 7: Initial Settings

Menu 8: Job status

Menu 9: Roll Length Manage

Menu 10: Media Adjustment

Menu 11: CR Maintenance

Menu 12: Soak Cleaning

Key operation

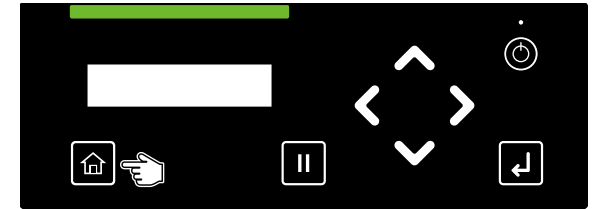

You will configure the various settings using the panel setup menu.

- 1 To enter the panel setup menu, tap  (the [Home] key).





Note

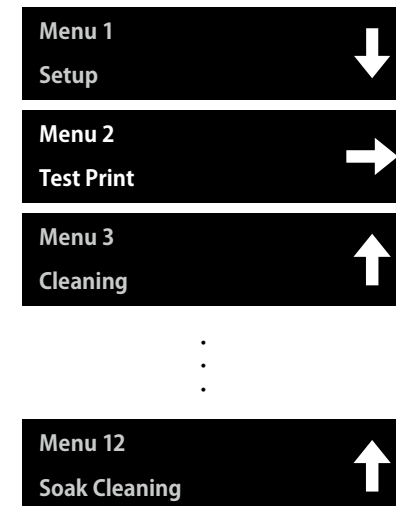

You cannot enter the panel setup menu while printing or receiving data (while the power button is blinking).

- 2 Use  or  key to scroll through the menu.
 - Use  key to enter the menu.



Before Use	Key operation
Basic Operations	Menu 1: Setup menus
Various settings	Menu 2: Test Print
Maintenance	Menu 3: Cleaning
When problems occur	Menu 4: Menu Option
Appendix	Menu 5: System Info.
	Menu 6: Sleep mode
	Menu 7: Initial Settings
	Menu 8: Job status
	Menu 9: Roll Length Manage
	Menu 10: Media Adjustment
	Menu 11: CR Maintenance
	Menu 12: Soak Cleaning

3 Use  /  keys to choose the option from a submenu or enter a numerical value.

-  ([Enter] key): Tap to confirm the setting or run the selected function.
-  key: Use to return to the upper level menu. (In the illustration on the right, it returns to "Menu 2: Test Print.")

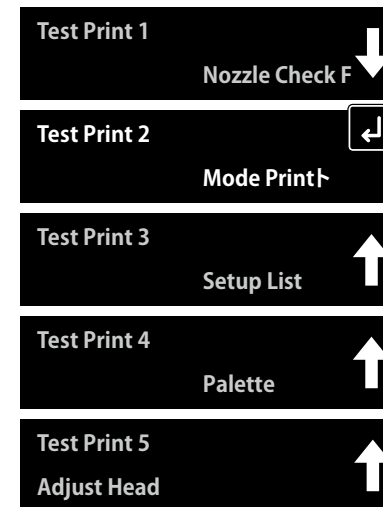

Before Use

Key operation

Basic Operations

Menu 1: Setup menus

Various settings

Menu 2: Test Print

Maintenance

Menu 3: Cleaning

When problems occur

Menu 4: Menu Option

Appendix

Menu 5: System Info.

Menu 6: Sleep mode

Menu 7: Initial Settings

Menu 8: Job status

Menu 9: Roll Length Manage

Menu 10: Media Adjustment

Menu 11: CR Maintenance

Menu 12: Soak Cleaning

Menu 1: Setup menus

Menu List

Underlines in the setting range are default values.

Item	Range of values	Description
User Type	<u>Type1</u> to Type15	Create your own media preset for each media type and save it with appropriate printer settings as "Type xx". You can define up to 15 user types.
Adjust Print  "Print quality calibration (Adjust Print)" P.97		Perform bidirectional printing calibration to align dot placement position. You will enter the thickness of media before calibration. <div style="border: 1px solid green; padding: 5px;">Note Warm up the heater and then start printing. Heating can be skipped, but this is not recommended because it will change the position of the dot landing.</div>
Auto	Adjust Pattern A	Run an automatic print quality calibration (Adjust Print) by reading the adjustment pattern using the color sensor. If performing the auto calibration does not improve print quality (banding or graininess appears), run an [Auto] calibration again or perform [Custom] calibration.
Custom	Confirm Pattern, Rough Pattern A, Fine Pattern A	Print an adjustment pattern and enter the number of the pattern that has the least misalignment. <ul style="list-style-type: none">• Confirm patternn: Prints a confirm pattern. Check for misalignment.• Rough pattern: Perform this if misalignment is large. Enter the number of the pattern that has the least misalignment.• Fine pattern: Perform this if misalignment is small. This menu prints an adjustment pattern at both ends and in the center of the media. Enter the number of the pattern that has the least misalignment.

Before Use

Key operation

Basic Operations

Menu 1: Setup menus

Various settings

Menu 2: Test Print

Maintenance

Menu 3: Cleaning

When problems occur

Menu 4: Menu Option

Appendix

Menu 5: System Info.

Menu 6: Sleep mode

Menu 7: Initial Settings

Menu 8: Job status

Menu 9: Roll Length Manage



Menu 10: Media Adjustment

Menu 11: CR Maintenance

Menu 12: Soak Cleaning

Item	Range of values	Description
PF Adjust ☞ "Media feed adjustment" P.102		This adjustment corrects the amount of media feed.
Auto		The color sensor reads the adjustment pattern print and the printer runs automatic media feed correction.
Initial Print	100 to <u>250</u> to 500 mm	Specify the media feeding length and print an initial adjustment pattern.
Initial Change	Initial adjustment print ± 50.0 mm	Measure the adjustment pattern printed and enter the measured length.
Confirm Print	100 to <u>250</u> to 500 mm	Print a confirmation pattern to check the adjustment.
Micro Print	11 patterns: ± 0 %, ± 0.1 %, ± 0.2 %, ± 0.5 %, ± 0.8 %, and ± 1.2 %.	Print the adjustment pattern for fine adjustment.
Micro Change	- 5.00 to <u>0.00</u> to 5.00 %	Check the adjustment pattern for fine adjustment and enter the best fine adjustment value.
Preheater	Off, <u>30</u> to 50° C	Preheats media to control rapid temperature changes.
Platen Heater	Off, <u>30</u> to 50° C	Suppresses blurring of printed ink.
Dryer	Off, <u>30</u> to 50° C	Allow the printed ink to dry.
Vacuum Fan	Off, Low, Medium, <u>High</u> , Ex High	Select the suction power level to hold down media. For soft media, reduce the suction power.
Thickness	80 to <u>170</u> to 1300 um	Enter the thickness of the media being loaded. If the setting has already been made in the Adjust Print menu, no entry is required. ☞ "Adjust Print" P.89
Copy User Type	Type1 to Type15, ALL	The following settings of the selected user type can be copied to another user type: Adjustment value of Adjust Print/ PF Adjust / Vacuum fan / Thickness/ Various heater settings. When [ALL] is selected, these settings will be copied to all user types.

Before Use	Key operation
Basic Operations	Menu 1: Setup menus
Various settings	Menu 2: Test Print
Maintenance	Menu 3: Cleaning
When problems occur	Menu 4: Menu Option
Appendix	Menu 5: System Info.
	Menu 6: Sleep mode
	Menu 7: Initial Settings
	Menu 8: Job status
	Menu 9: Roll Length Manage
	Menu 10: Media Adjustment
	Menu 11: CR Maintenance
	Menu 12: Soak Cleaning

Item	Range of values	Description													
Spitting	<u>On</u> , On Media, Off	<p>Enable or disable the ink flushing maintenance.</p> <ul style="list-style-type: none"> On: Select this to perform an ink flushing on the flushing box. Normally, the Pass Count menu should be set to [1]. MUTOH cannot guarantee print quality if it is set to more than [1]. On Media: Select this to perform an ink flushing on the flushing box and media margins. The maximum printing width is shortened by 16 mm.  "Side Margin" P.92 Off: Printer does not perform an ink flushing maintenance. With this setting, nozzle clogs easily. Normally, do not select [Off]. <div style="border: 1px solid #92d050; padding: 5px; margin-top: 10px;"> <p> Note</p> <p>Flushing is the print head maintenance to avoid nozzle clogging. It consumes some ink.</p> </div>													
Pass Count	<u>1</u> to 999 cnt	<p>Specify the interval to perform flushing on the flushing box. This option does not appear when the Spitting menu is set to [Off].</p> <table border="1" style="width: 100%; border-collapse: collapse;"> <thead> <tr> <th style="background-color: #d9e1f2;">Spitting</th> <th style="background-color: #d9e1f2;">Pass Count:</th> <th style="background-color: #d9e1f2;">Operation</th> </tr> </thead> <tbody> <tr> <td rowspan="2">On</td> <td>One cnt</td> <td>Printer performs flushing on the flushing box each time the print head travels back and forth.</td> </tr> <tr> <td>5 cnt</td> <td>Printer performs flushing on the flushing box once the print head travels back and forth five times.</td> </tr> <tr> <td rowspan="2">On Media</td> <td>1 cnt</td> <td>Printer performs flushing on the flushing box and on the media margin each time the print head travels back and forth.</td> </tr> <tr> <td>5 cnt</td> <td>Printer performs flushing on the flushing box once the print head travels back and forth five times. Flushing is performed on the media margin each time the print head travels back and forth.</td> </tr> </tbody> </table>	Spitting	Pass Count:	Operation	On	One cnt	Printer performs flushing on the flushing box each time the print head travels back and forth.	5 cnt	Printer performs flushing on the flushing box once the print head travels back and forth five times.	On Media	1 cnt	Printer performs flushing on the flushing box and on the media margin each time the print head travels back and forth.	5 cnt	Printer performs flushing on the flushing box once the print head travels back and forth five times. Flushing is performed on the media margin each time the print head travels back and forth.
Spitting	Pass Count:	Operation													
On	One cnt	Printer performs flushing on the flushing box each time the print head travels back and forth.													
	5 cnt	Printer performs flushing on the flushing box once the print head travels back and forth five times.													
On Media	1 cnt	Printer performs flushing on the flushing box and on the media margin each time the print head travels back and forth.													
	5 cnt	Printer performs flushing on the flushing box once the print head travels back and forth five times. Flushing is performed on the media margin each time the print head travels back and forth.													

Before Use

Key operation

Basic Operations

Menu 1: Setup menus

Various settings

Menu 2: Test Print

Maintenance

Menu 3: Cleaning

When problems occur

Menu 4: Menu Option

Appendix

Menu 5: System Info.

Menu 6: Sleep mode

Menu 7: Initial Settings

Menu 8: Job status

Menu 9: Roll Length Manage

Menu 10: Media Adjustment

Menu 11: CR Maintenance

Menu 12: Soak Cleaning

Item	Range of values	Description
Side Margin	5 to 25 mm	<p>Sets the left and right margins of the media.</p> <div style="border: 1px solid green; padding: 5px;"> <p>Important!!</p> <p>If media skewed, you will get ink smudge on the media that is held down by the edge holder. In such cases, the side margin should be set to more than 10 mm.</p> </div> <div style="border: 1px solid green; padding: 5px; margin-top: 5px;"> <p>Note</p> <p>If the Spitting Menu is set to [On Media], the maximum print width will be 16 mm shorter. The left and right margins are "set value + 8 mm". "Spitting" P.91</p> </div>
Media Initial	Off, <u>Top&Width</u> , <u>Width</u>	<p>Select how the printer detects the width of media.</p> <ul style="list-style-type: none"> Off: No detection is performed. Enter the media width in the [Media Width] menu. Top&Width: Automatically detects the width and the leading edge of media. Width: Automatically detects media width.
Media Width	210 to <u>1000</u> to 1625 mm	<p>Enter the width of media being loaded. If the Media Initial menu is set to [Width] or [Top & Width], the media width that the printer automatically detected will be displayed.</p> <p> / key in, then tap Enter.</p>
Output Mode	Off, <u>Take Up</u> , Auto Cut	<p>Select the how the printed media is processed.</p> <ul style="list-style-type: none"> Off: Select this when you do not use the take-up unit. Take Up: Select this when you use the take-up unit. Auto cut: Automatically cuts media after printing.
InkDryTimer	<u>0</u> to 60 min	<p>Set the time interval between after printing and before next printing for ink drying. Next printing will start when the specified time has passed.</p>

Before Use

Key operation

Basic Operations

Menu 1: Setup menus

Various settings

Menu 2: Test Print

Maintenance

Menu 3: Cleaning

When problems occur

Menu 4: Menu Option

Appendix

Menu 5: System Info.

Menu 6: Sleep mode

Menu 7: Initial Settings

Menu 8: Job status

Menu 9: Roll Length Manage

Menu 10: Media Adjustment

Menu 11: CR Maintenance

Menu 12: Soak Cleaning

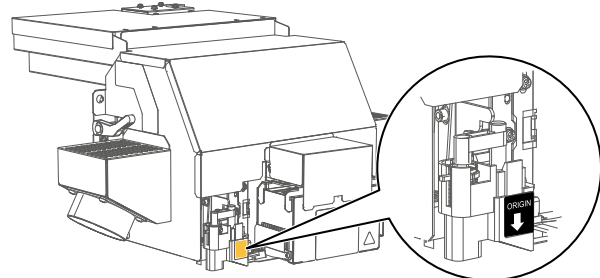
Item	Range of values	Description
Method of Cut	Single Cut to 2 steps <u>Single Cut to 3 steps</u> Double Cut to 2 steps Double Cut to 3 steps	<p>Sets the media cut operation after printing.</p> <ul style="list-style-type: none"> Single Cut - 2 steps: Cut with less process than "Single Cut - 3 steps". Suitable for narrower width media. Single Cut - 3 steps: Normal cutting method. Double Cut - 2 steps: Select this when "Single Cut - 2 steps" cannot fully cut the media. Double Cut - 3 steps: Select this when "Single Cut - 3 steps" cannot fully cut the media. <div style="border: 1px solid green; padding: 5px;"> <p>Note</p> <ul style="list-style-type: none"> If the Media Initial menu is set to [Off], media cutting will not be performed. 🖱️ "Media Initial" P.92 This option may not cut off some types of media. In such cases, set the Output Mode menu to [Off] and cut the media manually. 🖱️ "Output Mode" P.92 </div>
Cut Pressure	Low, <u>High</u>	<p>Sets the pressure to cut the media.</p> <ul style="list-style-type: none"> Low: Select this mode, when the High mode gives too much pressure or when you are using thin media. High: Normal cutting pressure.
Origin	PF, CR	<p>Sets the print start position (origin).</p> <ul style="list-style-type: none"> ⏪ / ⏩ key: Change the print start position (origin) in the media feeding direction (PF). ⏪ / ⏩ key: Change the print start position (origin) in the print head moving direction (CR). ⏴ ([Enter] key): Tap the key so that the carriage will move to the specified print start position. 

Before Use

Key operation

Basic Operations

Menu 1: Setup menus

Various settings

Menu 2: Test Print

Maintenance

Menu 3: Cleaning

When problems occur

Menu 4: Menu Option

Appendix

Menu 5: System Info.

Menu 6: Sleep mode

Menu 7: Initial Settings

Menu 8: Job status

Menu 9: Roll Length Manage

Menu 10: Media Adjustment

Menu 11: CR Maintenance



Menu 12: Soak Cleaning

Item	Range of values	Description
Prevent Stick	Off, On	Feed media back and forth before printing to prevent media sticking. This menu is disabled if the [Output Mode] menu is set to [Take Up].
Standby Heating	10 to 60 min	Sets the heater off time after printing.
Head Travel	Data, Machine, Media	Select the width that the print head travels for printing. <ul style="list-style-type: none"> Data: Travels the data width. Machine: Travels the full printer width. Media: Travels the media width.
Multi Strike	1 to 9 cnt	Specify the number of times the printer prints the same line. Increase the number of times if you want to perform high density printing on transparent media.
Pass Wait	0.0 to 5.0 sec	Sets the amount of time the carriage is paused each time it scans. Ink bleeding can be improved when ink does not dry easily, such as in layered applications.
Slant Check	Off, On	The printer checks skew after printing. If media skew is detected, an error message will be displayed.
Auto Cleaning		Set the type and timer of automatic cleaning. It prevents nozzle clogging.
Standby Mode		Sets the automatic cleaning to be performed while in ready-to-print state. Interval includes power off time. Auto-cleaning is not performed when the power is turned off, but is performed the next time the power is turned on.
Cleaning Type	Off, Short, Normal, Long	Select the type of automatic cleaning.
Cleaning interval	10 to 360 to 1440 min	Set the timer for automatic cleaning.
While Printing		Sets the automatic cleaning to be performed during printing. When the print time setting is exceeded, cleaning begins. When cleaning is complete, printing resumes.
Cleaning Type	Off, Short, Normal, Long	Sets the type of cleaning.
Cleaning interval	5 to 180 min	Sets the cleaning interval.
Before Print		Sets the automatic cleaning to be performed before printing.
Cleaning Type	Off, Short, Normal, Long	Sets the type of cleaning.

Before Use	Key operation
Basic Operations	Menu 1: Setup menus
Various settings	Menu 2: Test Print
Maintenance	Menu 3: Cleaning
When problems occur	Menu 4: Menu Option
Appendix	Menu 5: System Info.
	Menu 6: Sleep mode
	Menu 7: Initial Settings
	Menu 8: Job status
	Menu 9: Roll Length Manage
	Menu 10: Media Adjustment
	Menu 11: CR Maintenance
	Menu 12: Soak Cleaning

Item	Range of values	Description
Exhaust Fan	Off, <u>Low</u> , High	Exhausts the air inside the printer. Ink mist is also ejected, reducing contamination inside the printer. It is recommended to operate for long printing runs.
Longstore		Clean the print head. A Designated maintenance cleaner is required. 👉 "Long-term storage" P.175
Initialization		Restores various settings to factory defaults.
ALL		Initializes all settings.
User Type		Initialize all the user types.
Except UserType		Initialize the settings other than user type.
Header Dump	<u>Off</u> , on, Dump, Print	Select whether to print the following dump information for the print data; (Data header / Data dot number / print time / serial number / firmware version / receiving time / receiving size). <ul style="list-style-type: none"> • Off: This information will not be printed. • On: The printer prints an image data followed by dump information. "Receiving time" and "Receiving size" are not printed. • Dump: PThe printer prints dump information except data dot number. • Print: The printer prints the last dump information. "Receiving time" and "Receiving size" are not printed. The message [No data] will appear if there is no dump information in the history. <div style="border: 1px solid green; padding: 5px; margin-top: 10px;"> <p>Note</p> <ul style="list-style-type: none"> • Dump data is used for reference information when you receive technical support. • When you are printing through computer, the print settings configured in the RIP software will be printed here. </div>

Before Use	Key operation
Basic Operations	Menu 1: Setup menus
Various settings	Menu 2: Test Print
Maintenance	Menu 3: Cleaning
When problems occur	Menu 4: Menu Option
Appendix	Menu 5: System Info.
	Menu 6: Sleep mode
	Menu 7: Initial Settings
	Menu 8: Job status
	Menu 9: Roll Length Manage
	Menu 10: Media Adjustment
	Menu 11: CR Maintenance
	Menu 12: Soak Cleaning

Item	Range of values	Description
Heater Control	Normal, Fixer, Dryer	<p>Sets heater operation.</p> <ul style="list-style-type: none"> • Normal: Printing starts when the heater reaches the specified temperature. Use this option when you do not experience media cockling. • Fixer: Printing starts before the heater reaches the specified temperature. Printing colors may change. • Dryer: Use this option when you are using the take-up unit or you want to reduce a chance of media cockling without reducing ink drying.
Start Feed	0 to 500 mm	<p>Sets the margins between print data.</p> <div style="border: 1px solid green; padding: 5px;"> <p> Note</p> <ul style="list-style-type: none"> • When the Output Mode menu is set to [Off], the margin between print data will be the length specified in the Start Feed menu plus 10 mm. • When the Output Mode menu is set to [Take Up], the margin between print data will be the length specified in the Start Feed menu. • Margins between print data are set at 10 mm. <p> "Start printing" P.66</p> </div>
Temporary		Temporarily displays the menu set to hidden in the "Menu Option" menu.

Before Use	Key operation
Basic Operations	Menu 1: Setup menus
Various settings	Menu 2: Test Print
Maintenance	Menu 3: Cleaning
When problems occur	Menu 4: Menu Option
Appendix	Menu 5: System Info.
	Menu 6: Sleep mode
	Menu 7: Initial Settings
	Menu 8: Job status
	Menu 9: Roll Length Manage
	Menu 10: Media Adjustment
	Menu 11: CR Maintenance
	Menu 12: Soak Cleaning

Print quality calibration (Adjust Print)

This calibration adjusts dot placement position for bidirectional printing. Enter the thickness of the media before adjusting.

- **Be sure to perform this calibration in the following cases**

1. When using this product for the first time
2. When you changed with the different type of media
3. After you performed the "Adjust Head" calibration  ["Adjust Head" P.108](#)



- **If any of the following symptoms are observed, perform this calibration**

1. When graininess look or blurred lines appear on the print in bidirectional printing

■ **"Adjust Head" has following menus:**

Auto	Run an automatic print quality calibration (Adjust Print) by reading the adjustment pattern using the color sensor. If performing the auto calibration does not improve print quality (banding or graininess appears), run an [Auto] calibration again or perform [Custom] calibration.
Custom	Print an adjustment pattern and enter the number of the pattern that has the least misalignment. <ul style="list-style-type: none"> • Confirm pattern: Prints a confirm pattern. Check for misalignment. • Rough pattern: Perform this if misalignment is large. Enter the number of the pattern that has the least misalignment. • Fine pattern: Perform this if misalignment is small. This menu prints an adjustment pattern at both ends and in the center of the media. Enter the number of the pattern that has the least misalignment.

 **Note**

- To print an adjustment pattern, more than 550 mm width of printable area is required. If less than 550 mm, adjustment cannot be performed. Printable width on the media can be adjusted by changing CR origin and side margin (left and right side margin) settings.
 -  ["Media Width" P.92](#), ["Origin" P.93](#), ["Side Margin" P.92](#)
- Heater warming up is performed before printing the pattern. The printer control panel will display the message "Skip Heater Warm Up? No". Printing can be started during warm-up, but this is not recommended because the dot placement position may change.
 -  ["Start printing during warm-up" P.82](#)
- If the image quality does not improve after adjusting the "Print quality calibration (Adjust Print)", "Adjust Head" may improve the image quality.
 -  ["Adjust Head" P.108](#)

Before Use	Key operation
Basic Operations	Menu 1: Setup menus
Various settings	Menu 2: Test Print
Maintenance	Menu 3: Cleaning
When problems occur	Menu 4: Menu Option
Appendix	Menu 5: System Info.
	Menu 6: Sleep mode
	Menu 7: Initial Settings
	Menu 8: Job status
	Menu 9: Roll Length Manage
	Menu 10: Media Adjustment
	Menu 11: CR Maintenance
	Menu 12: Soak Cleaning

















Caution



Do not touch the media guide while printing or when the message "Warming Up" appears on the panel. There is a risk of burn injuries.

- 1** Load media and detect media width.
 **"Load the media into the printer" P.45**
 Make sure to load it without any warps or curls.
- 2** Access the "Adjust Print" menu in the user type menu.

 1. Tap  ([Home] key). "Setup" will be displayed.
 2. Tap  key to display "User Type Type 1".
 3. Tap  /  key to select any user type.
 4. Tap  ([Enter] key).
 5. Tap  /  key to select "Adjust Print".
- 3** Tap  the key to display "Thickness: ".
 Enter the media thickness.

 -  /  Key: Enter a value
 -  ([Enter] key): Confirm the setting
- 4** Tap  /  key to select the adjustment method.
 **"Print quality calibration (Adjust Print)" P.97**

Before Use	Key operation
Basic Operations	Menu 1: Setup menus
Various settings	Menu 2: Test Print
Maintenance	Menu 3: Cleaning
When problems occur	Menu 4: Menu Option
Appendix	Menu 5: System Info.
	Menu 6: Sleep mode
	Menu 7: Initial Settings
	Menu 8: Job status
	Menu 9: Roll Length Manage
	Menu 10: Media Adjustment
	Menu 11: CR Maintenance
	Menu 12: Soak Cleaning

5 Tap ([Enter] key) to start the adjustment.

- ([Cancel] key): Cancels printing.
- **When "Auto" is selected: the calibration is performed automatically.**
 - If the adjustment is successful, "AutoAdjust Succeeded OK -> Enter" is displayed.
 - If the adjustment fails, the message "AutoAdjust Failed OK -> Enter" is displayed. Redo the auto adjustment or perform a custom adjustment. The adjustment value for the pattern which has been failed to calibrate or has not been calibrated yet will not be saved in the printer.

Note

- If the image quality does not improve after performing the Auto Adjustment (e.g. banding, graininess, etc.), redo the Auto Adjustment or perform a Custom Adjustment.

- **When Custom is selected:**
 1. Prints the "Confirm patternn". Check for misalignment. If there is no misalignment, proceed to the next step.

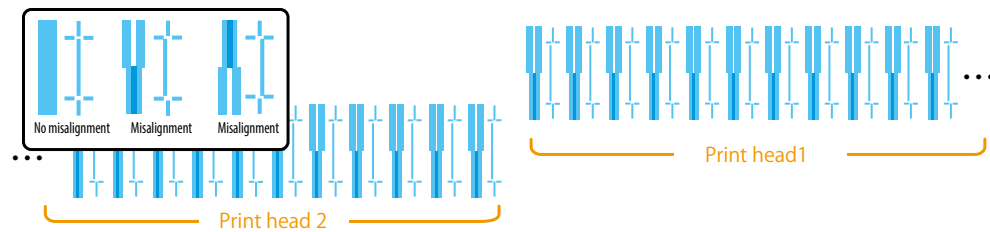

- If the amount of misalignment is large: Print a rough pattern. **"Rough pattern" P.100**
- If the amount of misalignment is small: Print a fine pattern. **"Fine pattern" P.101**

6 Tap ([Enter] key) to finish the adjustment.

Before Use

Key operation

Basic Operations

Menu 1: Setup menus

Various settings

Menu 2: Test Print

Maintenance

Menu 3: Cleaning

When problems occur

Menu 4: Menu Option

Appendix

Menu 5: System Info.

Menu 6: Sleep mode

Menu 7: Initial Settings

Menu 8: Job status

Menu 9: Roll Length Manage

Menu 10: Media Adjustment

Menu 11: CR Maintenance

Menu 12: Soak Cleaning

Rough pattern

1. Perform a rough adjustment.
 - Tap / key to select the "Rough Pattern".
 - Tap ([Enter] key) to print the adjustment pattern.
2. Look at the print for Print Head 1 and select the number written under the pattern that looks most aligned.

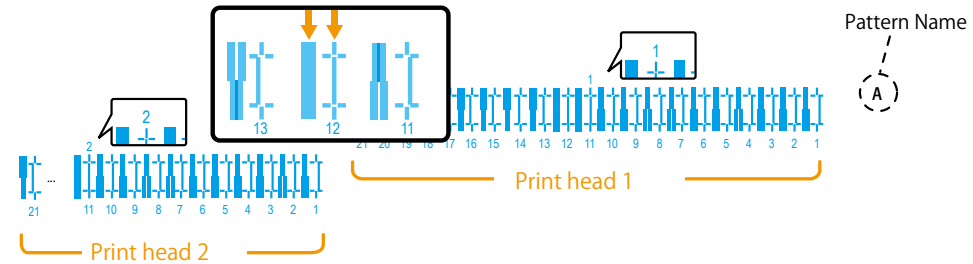

3. Enter the number of the pattern with no misalignment.
 - For the above illustration, you will enter "Pattern A: 12".
 - / : Change the number.
 - ([Enter] key): Confirm the change..
4. Enter the number for Print Head 2 in the same way.
5. Perform a fine adjustment.
 [Fine pattern P.101](#)

Before Use

Basic Operations

Various settings

Maintenance

When problems occur

Appendix

Key operation

Menu 1: Setup menus

Menu 2: Test Print

Menu 3: Cleaning

Menu 4: Menu Option

Menu 5: System Info.

Menu 6: Sleep mode

Menu 7: Initial Settings

Menu 8: Job status



Menu 9: Roll Length Manage

Menu 10: Media Adjustment



Menu 11: CR Maintenance

Menu 12: Soak Cleaning

Fine pattern

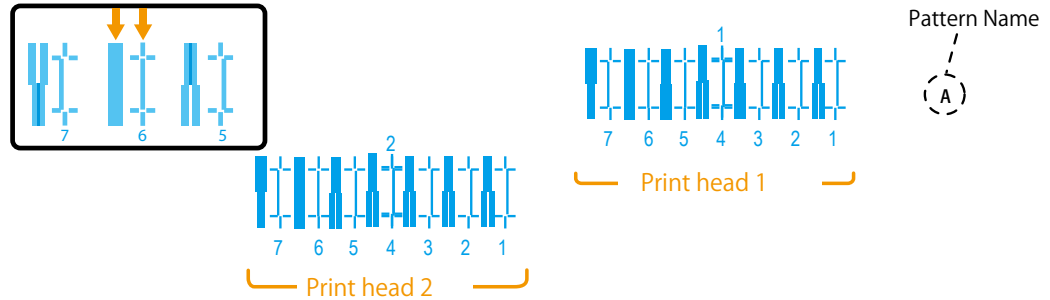
1. Perform fine-tuning.
 - Tap  /  key to select the "Fine pattern".
 - Tap  ([Enter] key) to print the adjustment pattern. Adjustment patterns are printed on both ends and in the center of the media.
2. Look at the results for Print Head 1 and select the number written under the pattern that looks most aligned.



3. Enter the number of the pattern with no misalignment.
 - For the above illustration, you will enter "Pattern A: 6".
 -  /  : Change the number.
 -  ([Enter] key): Confirm the change.
4. Perform an adjustment for Print Head 2 in the same way.

Before Use

Basic Operations

Various settings

Maintenance

When problems occur

Appendix

Key operation

Menu 1: Setup menus

Menu 2: Test Print

Menu 3: Cleaning

Menu 4: Menu Option

Menu 5: System Info.

Menu 6: Sleep mode

Menu 7: Initial Settings

Menu 8: Job status

Menu 9: Roll Length Manage

Menu 10: Media Adjustment

Menu 11: CR Maintenance



Menu 12: Soak Cleaning

Media feed adjustment



This adjustment corrects the amount of media feed.

- Run this adjustment if any of the following symptoms are observed
 1. When white or dark-colored lines appear the scanning direction of the carriage
- Be sure to run this adjustment in the following cases
 1. When using this product for the first time
 2. When you changed with the different type of media
 3. When you changed the pressure on the pressure rollers

■ "PF Adjust" has the following menus:

Auto	The color sensor reads the adjustment pattern print and the printer runs automatic media feed correction. <ul style="list-style-type: none">• The value after the Auto adjustment is automatically saved in Micro Change.  "Micro Change" P.102• The value of Initial Change may be initialized.  "Initial Change" P.102
Initial Print	Specify the media feeding length and print an initial adjustment pattern.
Initial Change	Measure the adjustment pattern printed and enter the measured length.
Confirm Print	Print a confirmation pattern to check the adjustment.
Micro Print	Print the adjustment pattern for fine adjustment.
Micro Change	Check the adjustment pattern for fine adjustment and enter the best fine adjustment value.

Note

- To print an adjustment pattern, more than 400 mm width of printable area is required. If less than 400 mm, adjustment cannot be performed. Printable width on the media can be adjusted by changing CR origin and side margin (left and right side margin) settings.
 -  ["Media Width" P.92](#), ["Origin" P.93](#), ["Side Margin" P.92](#)
- Heater warming up is performed before printing the pattern. The printer control panel will display the message "Skip Heater Warm Up? No". Printing can be started during warm-up, but this is not recommended because the dot placement position may change.
 -  ["Start printing during warm-up" P.82](#)

Before Use	Key operation
Basic Operations	Menu 1: Setup menus
Various settings	Menu 2: Test Print
Maintenance	Menu 3: Cleaning
When problems occur	Menu 4: Menu Option
Appendix	Menu 5: System Info.
	Menu 6: Sleep mode
	Menu 7: Initial Settings
	Menu 8: Job status
	Menu 9: Roll Length Manage
	Menu 10: Media Adjustment
	Menu 11: CR Maintenance
	Menu 12: Soak Cleaning



Caution



Do not touch the media guide while printing or when the message "Warming Up" appears on the panel. There is a risk of burn injuries.

1

Load media and detect media width.

["Load the media into the printer" P.45](#)

Make sure to load it without any warps or curls.

2

Access the PF Adjust menu in the User Type menu.

1. Tap ([Home] key). "Setup" will be displayed.
2. Tap key to display "User Type Type 1".
3. Tap / key to select any user type.
4. Tap ([Enter] key).
5. Tap / key to select "PF Adjust".

3

Tap / key to select the adjustment method.

["Media feed adjustment" P.102](#)

4

Tap ([Enter] key) to start the adjustment.

- ([Cancel] key): Cancels printing.
- **When "Auto" is selected: the calibration is performed automatically.**
 - If the adjustment is successful, "AutoAdjust Succeeded OK -> Enter" is displayed.
 - If the adjustment fails, the message "AutoAdjust Failed OK -> Enter" is displayed.

Note

If white or dark colored line still appears even after auto adjustment, perform media feed adjustment manually.

- **When you select a menu other than Auto:** ["Perform manual media feed adjustment" P.104](#)

5

Tap ([Enter] key) to finish the adjustment.

Before Use

Basic Operations

Various settings

Maintenance

When problems occur

Appendix

Key operation

Menu 1: Setup menus

Menu 2: Test Print

Menu 3: Cleaning

Menu 4: Menu Option

Menu 5: System Info.

Menu 6: Sleep mode

Menu 7: Initial Settings

Menu 8: Job status

Menu 9: Roll Length Manage



Menu 10: Media Adjustment

Menu 11: CR Maintenance

Menu 12: Soak Cleaning

Perform manual media feed adjustment

You will need a ruler for this adjustment. Please prepare a commercially available ruler.
If you already know the adjustment value, enter it in the "Micro Change" (Step9 (P.105)).





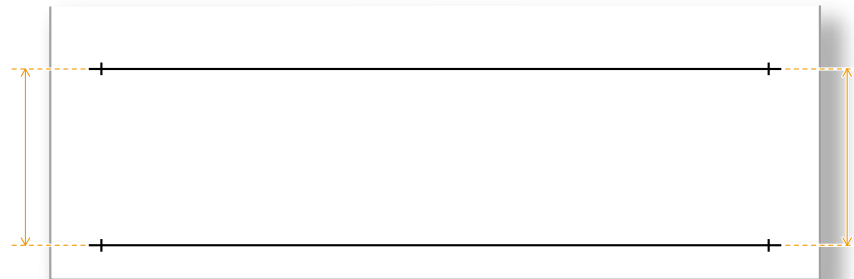

1. Perform an "Initial Print".
 - Tap  /  key to select "Initial Print".
 - Tap  ([Enter] key) to print the adjustment pattern.

Note

- The default value for feed length is set to 250 mm. Increasing the feed length slightly improves the accuracy of "Media feed adjustment".

2. Cut the media if needed.
3. Using a ruler, measure the length between the printed " + " .



4. Enter the measured length in "Initial Change".
 - Tap  /  key to select "Initial Change".
 - Enter the actual measured value and tap  ([Enter] key).
5. Perform a "Confirm Print".
 - Tap  /  key to select "Confirm Print".
 - Tap  ([Enter] key) to print the adjustment pattern.

Note

- The default value for feed length is set to 250 mm. Increasing the feed length slightly improves the accuracy of "Media feed adjustment".

Before Use

Basic Operations

Various settings

Maintenance

When problems occur

Appendix

Key operation

Menu 1: Setup menus

Menu 2: Test Print

Menu 3: Cleaning

Menu 4: Menu Option

Menu 5: System Info.

Menu 6: Sleep mode

Menu 7: Initial Settings

Menu 8: Job status

Menu 9: Roll Length Manage

Menu 10: Media Adjustment

Menu 11: CR Maintenance

Menu 12: Soak Cleaning

- Cut the media if needed.
- Using a ruler, measure the length between the printed " + " (as well as [Step3 \(P.104\)](#)).
 - If the length being displayed and the measured distance match: proceed to the next step.
 - If the length being displayed and the measured distance do not match: Start over from the "Initial Print" ([Step1 \(P.104\)](#)).
- Perform a "Micro Print".
 - Tap / key to select "Micro Print".
 - Tap ([Enter] key) to print the adjustment pattern.
 - Look at the print and select the value written under the pattern that has least white lines or overlapping.

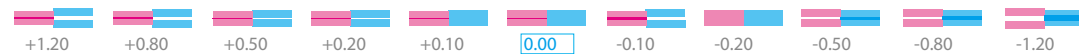
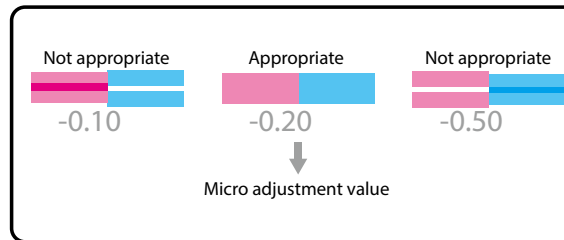

- Enter the selected value in the "Micro Change" field.
 - Tap / the key to select "Micro Change".
 - Enter a value and tap ([Enter] key).

Note

- Once the micro adjustment value has been saved, the value will become the reference value to be printed in the center of the pattern from the next print. For example, if you have entered "-0.20" and print a micro adjustment pattern, values printed below block pattern will be changed to (from left to right) +1.00, +0.60, +0.30, 0.00, -0.20 (reference value), -0.30, -0.40, -0.70, -1.00, -1.40.

Before Use

Key operation

Basic Operations

Menu 1: Setup menus

Various settings

Menu 2: Test Print

Maintenance

Menu 3: Cleaning

When problems occur

Menu 4: Menu Option

Appendix

Menu 5: System Info.

Menu 6: Sleep mode

Menu 7: Initial Settings

Menu 8: Job status

Menu 9: Roll Length Manage

Menu 10: Media Adjustment

Menu 11: CR Maintenance

Menu 12: Soak Cleaning

Menu 2: Test Print

Menu List

Item	Description																														
Nozzle check F ☞ "Performing Nozzle Check" P.61	Prints a nozzle check pattern using all nozzles.																														
Mode Print	Prints the following information set in the currently selected User Type. <ul style="list-style-type: none"> • Settings of each heater ☞ "Preheater" P.90,"Platen Heater" P.90,"Dryer" P.90 • Micro adjustment value of media feed adjustment ☞ "PF Adjust" P.90 <p style="text-align: right;">2021/10/08 0:00 Pre:30°C / Platen:30°C / Dryer:30°C / PF Adjust:0.00%</p>																														
Setup List	Prints the settings configured in the printer and specified in each user type. <div style="display: flex; justify-content: space-between;"> <div style="width: 48%;"> <pre> Setup List ----- [Detailed printer settings text including heater temperatures, media feed adjustments, and user type configurations] </pre> </div> <div style="width: 48%;"> <table border="1"> <thead> <tr> <th>Item</th> <th>User 1</th> <th>User 2</th> <th>User 3</th> <th>User 4</th> <th>User 5</th> </tr> </thead> <tbody> <tr> <td>Preheater</td> <td>30°C</td> <td>30°C</td> <td>30°C</td> <td>30°C</td> <td>30°C</td> </tr> <tr> <td>Platen Heater</td> <td>30°C</td> <td>30°C</td> <td>30°C</td> <td>30°C</td> <td>30°C</td> </tr> <tr> <td>Dryer</td> <td>30°C</td> <td>30°C</td> <td>30°C</td> <td>30°C</td> <td>30°C</td> </tr> <tr> <td>PF Adjust</td> <td>0.00%</td> <td>0.00%</td> <td>0.00%</td> <td>0.00%</td> <td>0.00%</td> </tr> </tbody> </table> </div> </div>	Item	User 1	User 2	User 3	User 4	User 5	Preheater	30°C	30°C	30°C	30°C	30°C	Platen Heater	30°C	30°C	30°C	30°C	30°C	Dryer	30°C	30°C	30°C	30°C	30°C	PF Adjust	0.00%	0.00%	0.00%	0.00%	0.00%
Item	User 1	User 2	User 3	User 4	User 5																										
Preheater	30°C	30°C	30°C	30°C	30°C																										
Platen Heater	30°C	30°C	30°C	30°C	30°C																										
Dryer	30°C	30°C	30°C	30°C	30°C																										
PF Adjust	0.00%	0.00%	0.00%	0.00%	0.00%																										

Before Use

Key operation

Basic Operations

Menu 1: Setup menus

Various settings

Menu 2: Test Print

Maintenance

Menu 3: Cleaning

When problems occur

Menu 4: Menu Option

Appendix

Menu 5: System Info.

Menu 6: Sleep mode

Menu 7: Initial Settings



Menu 8: Job status

Menu 9: Roll Length Manage

Menu 10: Media Adjustment

Menu 11: CR Maintenance

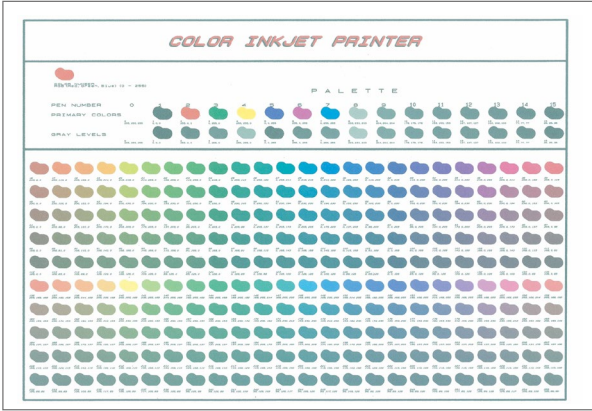
Menu 12: Soak Cleaning

Item	Description
Pallet	<p>Prints a color palette pattern.</p> 
Adjust Head	<p>This product is equipped with two printheads. This adjustment will calibrate dot placement between two print heads.</p> <p> "Adjust Head" P.108</p>
Custom	<p>Print the adjustment pattern and enter the number of the pattern that has least misalignment.</p>
Auto	<p>The color sensor reads the adjustment pattern and the printer automatically runs a print head alignment.</p>

Before Use	Key operation
Basic Operations	Menu 1: Setup menus
Various settings	Menu 2: Test Print
Maintenance	Menu 3: Cleaning
When problems occur	Menu 4: Menu Option
Appendix	Menu 5: System Info.
	Menu 6: Sleep mode
	Menu 7: Initial Settings
	Menu 8: Job status
	Menu 9: Roll Length Manage
	Menu 10: Media Adjustment
	Menu 11: CR Maintenance
	Menu 12: Soak Cleaning

Adjust Head



This product is equipped with two printheads. This adjustment will calibrate dot placement between two print heads.

- Be sure to perform this adjustment in the following cases
 1. When using this product for the first time
- Perform this adjustment if any of the following symptoms are observed
 1. When graininess look or blurred lines appear in the unidirectional printing.
 2. When you noticed the misalignment between two print heads.
 3. When the image quality does not improve even after "Print quality calibration (Adjust Print)" is performed.
 4. Ink dot does not spread when printing on thin media

■ "Adjust Head" has the following menus:

Auto	The color sensor detects the adjustment pattern and the printer runs automatic calibration.
Custom	Print the adjustment pattern and enter the number of the pattern that has least misalignment.

 **Note**

- After performing "Adjust Head" be sure to perform "Print quality calibration (Adjust Print)". Misalignment may occur in the bidirectional printing due to the head alignment.
 ["Print quality calibration \(Adjust Print\)" P.97](#)
- If the image quality does not improve after performing the Auto Adjustment (banding or graininess is observed), redo the Auto Adjustment or perform a Custom Adjustment.
- To print an adjustment pattern, more than 550 mm width of printable area is required. If less than 550 mm, adjustment cannot be performed. Printable width on the media can be adjusted by changing CR origin and side margin (left and right side margin) settings.
 ["Media Width" P.92](#), ["Origin" P.93](#), ["Side Margin" P.92](#)
- Heater warming up is performed before printing the pattern. The printer control panel will display the message "Skip Heater Warm Up? No". Printing can be started during warm-up, but this is not recommended because the dot placement position may change.
 ["Start printing during warm-up" P.82](#)

 **Caution**

 Do not touch the media guide while printing or when the message "Warming Up" appears on the panel. There is a risk of burn injuries.

Before Use	Key operation
Basic Operations	Menu 1: Setup menus
Various settings	Menu 2: Test Print
Maintenance	Menu 3: Cleaning
When problems occur	Menu 4: Menu Option
Appendix	Menu 5: System Info.
	Menu 6: Sleep mode
	Menu 7: Initial Settings
	Menu 8: Job status
	Menu 9: Roll Length Manage
	Menu 10: Media Adjustment
	Menu 11: CR Maintenance
	Menu 12: Soak Cleaning

Head adjustment procedure

- 1** Load media and detect media width.

☞ "Load the media into the printer" P.45

 - Make sure to load it without any warps or curls.

- 2** Access the "Adjust Head" menu.

 1. Tap ([Home] key). "Setup" will be displayed.
 2. Tap key to display "Test Print".
 3. Tap key to display "Nozzle check".
 4. Tap / key to select "Adjust Print".
 5. Tap key.

- 3** Tap / key to select the adjustment method.

☞ "Adjust Head" P.108

- 4** Tap ([Enter] key) to start the adjustment.

 - ([Cancel] key): Cancels printing.
 - **When "Auto" is selected: the calibration is performed automatically.**
 - If the adjustment is successful, "AutoAdjust Succeeded OK -> Enter" is displayed.
 - If the adjustment fails, the message "AutoAdjust Failed OK -> Enter" is displayed. Redo the auto adjustment or perform a custom adjustment. The adjustment value for the pattern which has been failed to calibrate or has not been calibrated yet will not be saved in the printer.
 - **When Custom is selected: The adjustment pattern will be printed on both ends and in the center of the media.**
 1. Check the printed results to find the pattern with the least misalignment.

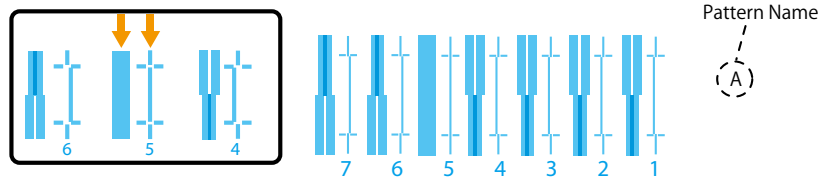

2. Tap / key and enter the number of the pattern with no misalignment.
 - For the above illustration, you will enter "Pattern A: 5".

Before Use	Key operation
Basic Operations	Menu 1: Setup menus
Various settings	Menu 2: Test Print
Maintenance	Menu 3: Cleaning
When problems occur	Menu 4: Menu Option
Appendix	Menu 5: System Info.
	Menu 6: Sleep mode
	Menu 7: Initial Settings
	Menu 8: Job status
	Menu 9: Roll Length Manage
	Menu 10: Media Adjustment
	Menu 11: CR Maintenance
	Menu 12: Soak Cleaning

5 Tap  ([Enter] key) to finish the adjustment.

Before Use

Key operation

Basic Operations

Menu 1: Setup menus

Various settings

Menu 2: Test Print

Maintenance

Menu 3: Cleaning

When problems occur

Menu 4: Menu Option

Appendix

Menu 5: System Info.

Menu 6: Sleep mode

Menu 7: Initial Settings

Menu 8: Job status

Menu 9: Roll Length Manage

Menu 10: Media Adjustment

Menu 11: CR Maintenance

Menu 12: Soak Cleaning

Menu 3: Cleaning

Clean the print head. You can select the heads to be cleaned and the type of cleaning.

Menu List

Item	Range of values	Description
Cleaning ☞ "Performing Head cleaning" P.63		
Head Select	All, Head 1, Head 2	Select the print head to be cleaned. If nozzle clogging is occurring in a particular printhead, ink consumption can be reduced by selecting the target printhead.
Cleaning Type ☞ "Head cleaning mode" P.63	Short, Normal, Long, Little Charge, Initial Charge	Select the cleaning type. Use it according to the print results of the nozzle check. Initial Charge is displayed when [All] is selected for head selection.

☞ Important!!





When performing Little Charge and Initial Charge, observe the following. A large amount of ink is consumed to re-fill the ink.



- Do not turn off the power.
- Do not unplug the power cord.
- Do not open the front cover or maintenance cover.
- Do not raise the pressure rollers.
- Do not pull out the ink bag case or smart chip card.
- Do not use ink bags with low ink levels.

Before Use	Key operation
Basic Operations	Menu 1: Setup menus
Various settings	Menu 2: Test Print
Maintenance	Menu 3: Cleaning
When problems occur	Menu 4: Menu Option
Appendix	Menu 5: System Info.
	Menu 6: Sleep mode
	Menu 7: Initial Settings
	Menu 8: Job status
	Menu 9: Roll Length Manage
	Menu 10: Media Adjustment
	Menu 11: CR Maintenance
	Menu 12: Soak Cleaning

Menu 4: Menu Option

You can select items to be displayed in the "Setup" menu.  [Menu 1: Setup menus P.89](#)

- 1** Access the "Menu Option" menu.
 1. Tap  ([Home] key). "Setup" will be displayed.
 2. Tap  /  key to display "Menu Option".
 3. Tap  key to select "User Type".

- 2** Tap  /  key to select an item to show/hide.

- 3** Tap  ([Enter] key) to show or not to show the item.
[*]: to be displayed, []: not to be displayed

 **Note**
"All On" and "All Off" can be used to show or hide all items at once.

Before Use

Basic Operations

Various settings

Maintenance

When problems occur

Appendix

Key operation

Menu 1: Setup menus

Menu 2: Test Print

Menu 3: Cleaning

Menu 4: Menu Option

Menu 5: System Info.

Menu 6: Sleep mode

Menu 7: Initial Settings

Menu 8: Job status

Menu 9: Roll Length Manage

Menu 10: Media Adjustment



Menu 11: CR Maintenance

Menu 12: Soak Cleaning

Menu 5: System Info.

Displays printer information.

Menu List

Item	Description
Version	Displays the version of the firmware (M: Main, C: Controller).
Printer Model	Displays the model name of the printer.
Serial Number	Displays the serial number of the printer.
Color	Displays the ink set being used..
Total Print Area	Displays the cumulative area printed from the time of purchase to the present.
Ink Status	Displays the amount of ink remaining in each ink bag (Unit: %). <ul style="list-style-type: none">Use genuine ink and smart chip cards. Ink status will not be displayed correctly if non-genuine products are used.If the ink level is blinking at 10%, Smart Chip Recovery is being performed for the corresponding ink bag.  "Smartchip Recovery" P.189
Life Times	Displays remaining life of the parts that need to be replaced. Parts life is indicated by the number of [*] marks (max. 5 (100 % remaining)). The number of [*] marks decreases by one (20 %) as the life of the component approaches. Example: <ul style="list-style-type: none">[Pump 1 E*****F]: 100 to 80 % life remaining[Pump 1 E** F]: 40 to 20 % life remaining[Pump 1 E* F]: 20 % or less life remaining[Pump 1 Change]: Request replacement of parts. When the parts need to be replaced, the message "Life Time [xxx]/ OK -> Enter" will appear on the panel. This message can be cleared by tapping the  ([Enter] key), but it will be prompted again in seven days.
Ink expiration	Displays ink expiration date.

Before Use

Basic Operations

Various settings

Maintenance

When problems occur

Appendix

Key operation

Menu 1: Setup menus

Menu 2: Test Print

Menu 3: Cleaning

Menu 4: Menu Option

Menu 5: System Info.

Menu 6: Sleep mode

Menu 7: Initial Settings

Menu 8: Job status

Menu 9: Roll Length Manage

Menu 10: Media Adjustment

Menu 11: CR Maintenance



Menu 12: Soak Cleaning

Menu 6: Sleep mode

Sleep mode allows head cleaning to be performed periodically even when the printer is not in use. During sleep mode, all keys except the power button and [Enter] key are disabled.

Menu List

Underlines in the setting range are default values.

Item	Range of values	Description
Cleaning Setting		Sets the automatic head cleaning to be performed during sleep mode.
Cleaning Type	<u>Short</u> , Normal, Long	Sets the type of automatic cleaning.
Cleaning Timer	1 to <u>6</u> to 24 hours	Sets the timer for automatic cleaning.
Start		Perform a daily maintenance before entering into sleep mode.  "Daily maintenance at the end of work" P.141 To wake up from sleep mode, tap  ([Enter] key). Sleep mode cannot be entered in the following cases <ul style="list-style-type: none">• Errors are occurring (Ink End, No Bag, Full Waste Ink Tank, Cover Open, etc.)• Printer is running (e.g., during Media Initial, printing, etc.)

Important!!

If any of the following conditions occur during sleep mode, head cleaning will not be executed (operation will be stopped during head cleaning). When restored to normal conditions, head cleaning will resume.

- Front cover or maintenance cover is open.
- The pressure rollers is up.
- Waste ink tank is full.
- Ink bag case is removed.
- Smart chip card is removed.
- A non-genuine smart chip card is inserted.

Before Use

Key operation

Basic Operations

Menu 1: Setup menus

Various settings

Menu 2: Test Print

Maintenance

Menu 3: Cleaning

When problems occur

Menu 4: Menu Option

Appendix

Menu 5: System Info.

Menu 6: Sleep mode

Menu 7: Initial Settings

Menu 8: Job status

Menu 9: Roll Length Manage

Menu 10: Media Adjustment

Menu 11: CR Maintenance

Menu 12: Soak Cleaning

Menu 7: Initial Settings

Configure printer settings.

Menu List

Underlines in the setting range are default values.

Item	Range of values	Description
Language	<u>English</u> , Dutch, Spanish, France, Italian, Portuguese, German, Japanese	Select the language to be displayed on the panel.
Temperature	<u>Celsius</u> [° C], Fahrenheit [° F]	Select the temperature unit to be displayed on the panel.
Length	<u>mm</u> , inch	Select the length unit to be displayed on the panel.
IP Address	0.0.0.0 ~ <u>192.168.1.253</u> ~ 255.255.255.255	
Subnet Mask	0.0.0.0 ~ <u>255.255.255.0</u> ~ 255.255.255.255	
Gateway	0.0.0.0 ~ <u>192.168.1.254</u> ~ 255.255.255.255	
Alert Buzzer	Off, <u>On</u>	Select how the alert buzzer beeps when an error occurs. <ul style="list-style-type: none">• On: The buzzer beeps continuously.• Off: The buzzer stops after a certain number of beeps. This prevents the alert buzzer from sounding continuously at night or when the operator is not present.

Important!!

Always consult your network administrator before setting the IP address, subnet mask, and gateway of the printer.

Before Use	Key operation
Basic Operations	Menu 1: Setup menus
Various settings	Menu 2: Test Print
Maintenance	Menu 3: Cleaning
When problems occur	Menu 4: Menu Option
Appendix	Menu 5: System Info.
	Menu 6: Sleep mode
	Menu 7: Initial Settings
	Menu 8: Job status
	Menu 9: Roll Length Manage
	Menu 10: Media Adjustment
	Menu 11: CR Maintenance
	Menu 12: Soak Cleaning

Menu 8: Job status

Displays various information on previous printout results.

Menu List

Item	Description
Status	Indicates whether printing is complete.
ToDoLength	Displays the total length of the print data (Media feed direction).
Done	Displays the length of the printed data.
Print Remain	Displays the length of data not printed.

Before Use

Key operation

Basic Operations

Menu 1: Setup menus

Various settings

Menu 2: Test Print

Maintenance

Menu 3: Cleaning

When problems occur

Menu 4: Menu Option

Appendix

Menu 5: System Info.

Menu 6: Sleep mode

Menu 7: Initial Settings

Menu 8: Job status

Menu 9: Roll Length Manage

Menu 10: Media Adjustment

Menu 11: CR Maintenance

Menu 12: Soak Cleaning

Menu 9: Roll Length Manage



This menu allows you to manage the remaining length information of roll media being loaded in the printer. You can print this information on the roll media with text and a code. The next time when the roll media is loaded, the printer will read the code and manage the remaining length.

Note

- The "Roll Length Manage" menu will not appear in the following cases.
 - When the Media Initial menu is set to "Off". ["Media Initial" P.92](#)
 - When no media is loaded ["Load the media into the printer" P.45](#)
- "Print" or "Simple Print" requires at least 400 mm printable width. If it is less than 400 mm, it will not be printed.
- Printable width on the media can be adjusted by changing CR origin and side margin (left and right side margin) settings. ["Media Width" P.92](#) , ["Origin" P.93](#), ["Side Margin" P.92](#)

Menu List





Underlines in the setting range are default values.

Item	Set value	Description
Print		<p>After cutting the print off the roll media, print a roll remaining length management information (roll media type, remaining length, date printed, roll length management code) on the roll media. This information cannot be printed when the "Rollkind" menu is set to [Off]. "Rollkind" P.118</p> 
Simple Print		<p>After cutting the print off the roll media, print a roll remaining length management information (roll media type, remaining length, date printed) on the roll media. This information cannot be printed when the "Rollkind" menu is set to [Off]. "Rollkind" P.118</p> 

Before Use	Key operation
Basic Operations	Menu 1: Setup menus
Various settings	Menu 2: Test Print
Maintenance	Menu 3: Cleaning
When problems occur	Menu 4: Menu Option
Appendix	Menu 5: System Info.
	Menu 6: Sleep mode
	Menu 7: Initial Settings
	Menu 8: Job status
	Menu 9: Roll Length Manage
	Menu 10: Media Adjustment
	Menu 11: CR Maintenance
	Menu 12: Soak Cleaning

Item	Set value	Description				
Scan ☞ "Scan" P.119		Read the roll length management code printed on the roll media. If the reading fails, the "Roll Length" menu appears. Please enter manually. ☞ "Rollkind" P.118				
Rollkind	Off, roll 1-3	<p>The length of up to three roll media to be loaded can be specified (Setting range: 1 m to 1500 m, changeable in 1 m increments). Once specified, the display goes to the End Detection menu.</p> <p>● End Detection Menu Select whether to pause printing when the remaining roll length counter reached zero.</p> <ul style="list-style-type: none"> On (Default): Detects the presence of media. In the [On] setting, the display will go to the Print Stop menu. Off: Does not detect the presence of media. In the [Off] setting, the Print Stop menu is fixed to [On] and the display will go to the Near End menu. <div style="border: 1px solid green; padding: 5px; margin: 10px 0;"> <p>Important !!</p> <ul style="list-style-type: none"> In the off setting, there is a risk of printing on the platen as the printer does not detect the presence of media. Enter the media length shorter than actual length. When set to [Off], an exclamation mark (!) appears on the panel. <table border="0" style="width: 100%;"> <tr> <td style="text-align: center;">When set to [On]</td> <td style="text-align: center;">When set to [Off]</td> </tr> <tr> <td style="text-align: center;"> <div style="background-color: black; color: white; padding: 5px; display: inline-block;"> Print Ready PG: Low L : XX m </div> </td> <td style="text-align: center;"> <div style="background-color: black; color: white; padding: 5px; display: inline-block;"> Print Ready PG: Low L!: XX m </div> </td> </tr> </table> </div> <p>● Print Stop Menu when the remaining roll length counter reached zero.</p> <ul style="list-style-type: none"> Off (Default): Printing pauses when the rear sensor responds. On: When the remaining length counter reached zero, the printer gives [Roll Remain Error] message and pauses printing. If a roll media does not release easily from the paper core, you should select [On]. In the [On] setting, the display will go to the Near End menu. <p>● Near End menu Select whether to display the remaining roll length on the control panel before the counter reaches 0.</p> <ul style="list-style-type: none"> Off (Default): Remaining length is not displayed. Remain **m (** can be specified between 1 to 10): "Near End" is displayed when the counter reached the length you specified. 	When set to [On]	When set to [Off]	<div style="background-color: black; color: white; padding: 5px; display: inline-block;"> Print Ready PG: Low L : XX m </div>	<div style="background-color: black; color: white; padding: 5px; display: inline-block;"> Print Ready PG: Low L!: XX m </div>
When set to [On]	When set to [Off]					
<div style="background-color: black; color: white; padding: 5px; display: inline-block;"> Print Ready PG: Low L : XX m </div>	<div style="background-color: black; color: white; padding: 5px; display: inline-block;"> Print Ready PG: Low L!: XX m </div>					



Before Use	Key operation
Basic Operations	Menu 1: Setup menus
Various settings	Menu 2: Test Print
Maintenance	Menu 3: Cleaning
When problems occur	Menu 4: Menu Option
Appendix	Menu 5: System Info.
	Menu 6: Sleep mode
	Menu 7: Initial Settings
	Menu 8: Job status
	Menu 9: Roll Length Manage
	Menu 10: Media Adjustment
	Menu 11: CR Maintenance
	Menu 12: Soak Cleaning

Item	Set value	Description
Auto Scan	Off, On	<p>Select whether or not the printer automatically scans the remaining length management code.</p> <ul style="list-style-type: none"> Off: The printer does not automatically read the code. On: The printer automatically scans the code. Tapping the  ([Cancel] key) will cancel the reading. <div style="border: 1px solid green; padding: 5px;"> <p>Note</p> <p>Read timing</p> <ul style="list-style-type: none"> When the printer is turned on When the roll media is replaced <p>If the "Auto Scan" is set to "On" but the printer does not read the code, check if the following settings are set to "Off" or "Auto Cut".</p> <p> "Media Initial" P.92, "Output Mode" P.92</p> </div>
Auto Print	Off, On	<p>Select whether or not to prompt a confirmation message when you perform media cutting, asking you whether to print a remaining length management information on a roll media.</p> <ul style="list-style-type: none"> Off (Default): This message is not prompted. On: The confirmation message [Print Roll's Remain?] appears after you perform media cutting. Select "Yes" or "No" and tap  ([Enter] key). <div style="border: 1px solid green; padding: 5px;"> <p>Note</p> <p>If the "Roll Length" menu is set to [Off], the Auto Print menu cannot be set to [On].</p> <p> "Rollkind" P.118</p> </div>

Scan

Scan the remaining length management code.

- Load a roll media that the remaining length management code has been printed on into the printer.

 -  ["Load the media into the printer" P.45](#)
 -  ["Menu 9: Roll Length Manage" P.117, Print P.117](#)
 - Make sure to load it without any warps or curls.

Before Use

Key operation

Basic Operations

Menu 1: Setup menus

Various settings

Menu 2: Test Print

Maintenance

Menu 3: Cleaning

When problems occur

Menu 4: Menu Option

Appendix

Menu 5: System Info.

Menu 6: Sleep mode

Menu 7: Initial Settings

Menu 8: Job status

Menu 9: Roll Length Manage

Menu 10: Media Adjustment

Menu 11: CR Maintenance

Menu 12: Soak Cleaning

- 2 Check that the code printed on the media has passed through the pressure rollers.

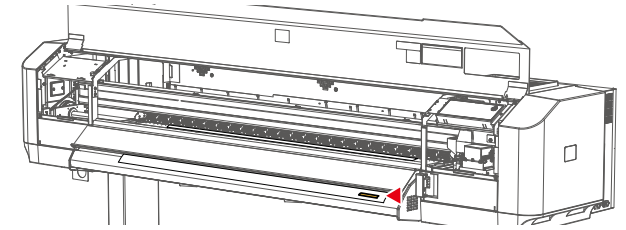

- 3 Access the Scan menu in the "Roll Length Manage" menu.

1. Tap ([Home] key). "Setup" will be displayed.
2. Tap / key to display "Roll Length Manage".
3. Tap key to display "Print".
4. Tap / key to select "Read".

- 4 Tap ([Enter] key) to start reading.

- ([Cancel] key): Cancels the reading.

When the printer scanned the code successfully, the following settings will automatically be specified in Roll Length:

["Menu 9: Roll Length Manage" P.117](#)

- Type of roll media
- Remaining roll length

Note

- The printer may fail to scan if a remaining length management code has dirt or fold marks on it. In case failed to scan the code, manually specify the Roll Length settings based on the remaining length management information printed in text on the media.

["Rollkind" P.118](#)

Before Use

Key operation

Basic Operations

Menu 1: Setup menus

Various settings

Menu 2: Test Print

Maintenance

Menu 3: Cleaning

When problems occur

Menu 4: Menu Option

Appendix

Menu 5: System Info.

Menu 6: Sleep mode

Menu 7: Initial Settings

Menu 8: Job status

Menu 9: Roll Length Manage

Menu 10: Media Adjustment

Menu 11: CR Maintenance

Menu 12: Soak Cleaning

Menu 10: Media Adjustment

The printer automatically runs print quality calibration and media feed adjustment.

☞ "Print quality calibration (Adjust Print)" P.97, "Media feed adjustment" P.102

Note

- This menu prints an adjustment pattern. To print it, more than 550 mm of printable area is required. If less than 550 mm, calibration cannot be performed. Printable width on the media can be adjusted by changing CR origin and side margin (left and right side margin) settings.
 - ☞ [Media Width P.92](#), [Origin P.93](#), [Side Margin P.92](#)
- If the image quality does not improve after adjusting the "Print quality calibration (Adjust Print)", "Adjust Head" may improve the image quality.
 - ☞ ["Adjust Head" P.108](#)
- Heater warming up is performed before printing the pattern. The printer control panel will display the message "Skip Heater Warm Up? No". Printing can be started during warm-up, but this is not recommended because the dot placement position may change.
 - ☞ ["Start printing during warm-up" P.82](#)
- The User Type and media thicknesses selected here are reflected in the set values.



Caution



Do not touch the media guide while printing or when the message "Warming Up" appears on the panel. There is a risk of burn injuries.

1





Load a roll media.

☞ [Load the media into the printer P.45](#)

- Make sure to load it without any warps or curls.



Before Use	Key operation
Basic Operations	Menu 1: Setup menus
Various settings	Menu 2: Test Print
Maintenance	Menu 3: Cleaning
When problems occur	Menu 4: Menu Option
Appendix	Menu 5: System Info.
	Menu 6: Sleep mode
	Menu 7: Initial Settings
	Menu 8: Job status
	Menu 9: Roll Length Manage
	Menu 10: Media Adjustment
	Menu 11: CR Maintenance
	Menu 12: Soak Cleaning

2 Access the "Media Adjustment" menu.



1. Tap  ([Home] key). "Setup" will be displayed.
2. Tap  /  key to display "Media Adjustment".
3. Tap  key to display "User Type Type 1".

3 Tap / key to select any user type.

4 Tap ([Enter] key) to enter the media thickness.

-  /  Key: Enter a value
-  ([Enter] key): Confirm the setting

5 Tap ([Enter] key) to start automatic adjustment.

-  ([Cancel] key): Cancels printing.
- If the adjustment is successful, "AutoAdjust Succeeded OK -> Enter" is displayed.
- If the adjustment fails, the message "AutoAdjust Failed OK -> Enter" is displayed. Please redo it manually ( [Print quality calibration \(Adjust Print\) P.97](#) and  [Media feed adjustment P.102](#)). The adjustment value for the pattern which has been failed to calibrate or has not been calibrated yet will not be saved in the printer.

Note

- If the image quality does not improve after performing the Auto Adjustment (e.g. banding, graininess, etc.), redo the Auto Adjustment or perform a Custom Adjustment.
- The initial values for User Type and media thickness reflect the currently selected User Type values.

6 Tap ([Enter] key) to exit automatic adjustment.

Before Use

Basic Operations

Various settings

Maintenance

When problems occur

Appendix

Key operation

Menu 1: Setup menus

Menu 2: Test Print

Menu 3: Cleaning

Menu 4: Menu Option

Menu 5: System Info.

Menu 6: Sleep mode

Menu 7: Initial Settings

Menu 8: Job status

Menu 9: Roll Length Manage

Menu 10: Media Adjustment

Menu 11: CR Maintenance

Menu 12: Soak Cleaning





Menu 11: CR Maintenance

Move the carriage and perform maintenance on the printer.

Use this menu to perform the following maintenance:

- "Daily maintenance at the end of work" P.141
- "Clean the UV-LED unit" P.143
- "Clean the parts around the print head" P.146
- "Clean the cleaning wiper and the parts around the capping unit" P.147
- "Clean the color sensor" P.153
- "Replace the wiper pad" P.160
- "Replace the Cutter" P.163
- "Replace the UV-LED unit filter" P.166
- "Replace the UV-LED unit glass" P.168
- "Replace the flushing box" P.170

1 Access the "CR Maintenance" menu.

1. Tap  ([Home] key). "Setup" will be displayed.
2. Tap  /  key to display "CR Maintenance".
3. Tap  key to display "Start".

2 Tap ([Enter] key) to start maintenance.

- "End -> Enter" will be displayed.
- The carriage moves to the maintenance space and the wipers move to the maintenance position.

Daily Maintenance

Start

->

Enter

3 Open the covers and perform a maintenance.

- Tapping  key drives the pump and stops it after 2 seconds.
- The message "Close Cover" will appear if the cover is open for more than ten minutes.

Before Use	Key operation
Basic Operations	Menu 1: Setup menus
Various settings	Menu 2: Test Print
Maintenance	Menu 3: Cleaning
When problems occur	Menu 4: Menu Option
Appendix	Menu 5: System Info.
	Menu 6: Sleep mode
	Menu 7: Initial Settings
	Menu 8: Job status
	Menu 9: Roll Length Manage
	Menu 10: Media Adjustment
	Menu 11: CR Maintenance
	Menu 12: Soak Cleaning

4 Close all covers when maintenance is complete.

5 Tap  ([Enter] key) to exit maintenance.

 **Note**

After 30 seconds of closing the cover, maintenance is automatically terminated.

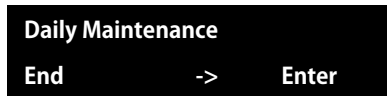

 **Important !!**

When you open the front cover, there is the metal part popped out on the upper right of the printer control panel. Do not touch it to avoid injury.

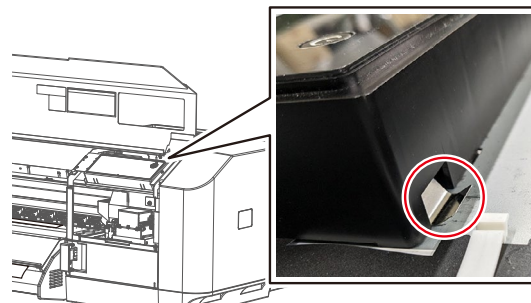

Before Use

Basic Operations

Various settings

Maintenance

When problems occur

Appendix

Key operation

Menu 1: Setup menus

Menu 2: Test Print

Menu 3: Cleaning

Menu 4: Menu Option

Menu 5: System Info.

Menu 6: Sleep mode

Menu 7: Initial Settings

Menu 8: Job status

Menu 9: Roll Length Manage

Menu 10: Media Adjustment

Menu 11: CR Maintenance

Menu 12: Soak Cleaning

Menu 12: Soak Cleaning

Soak the print head in the maintenance cleaner filled in the head cap to clean dirt on the surface of nozzle.

1 Prepare the necessary items for maintenance.

 [Preparations for maintenance P.131](#)



What you need:

- Polyethylene gloves, Rubber gloves, Protective goggles, Protective mask
- Dropper
- Designated maintenance cleaner

2 Wear protective equipment.

 ["Wearing protective equipment" P.132](#)

3 Access the "Soak Cleaning" menu.

1. Tap  ([Home] key). "Setup" will be displayed
2. Tap  /  key to display "Soak Cleaning".
3. Tap  key to display "Start".

4 Tap  ([Enter] key) to start cleaning.

- The carriage moves to the maintenance space on the left side.
- "Pour Cleaning Fluid End -> Enter" appears.

Soak Cleaning

Start

->

Enter

5 Open the front cover.

Before Use

Basic Operations

Various settings

Maintenance

When problems occur

Appendix

Key operation

Menu 1: Setup menus

Menu 2: Test Print

Menu 3: Cleaning

Menu 4: Menu Option

Menu 5: System Info.

Menu 6: Sleep mode

Menu 7: Initial Settings

Menu 8: Job status

Menu 9: Roll Length Manage

Menu 10: Media Adjustment

Menu 11: CR Maintenance

Menu 12: Soak Cleaning

6 Open the right side maintenance cover.

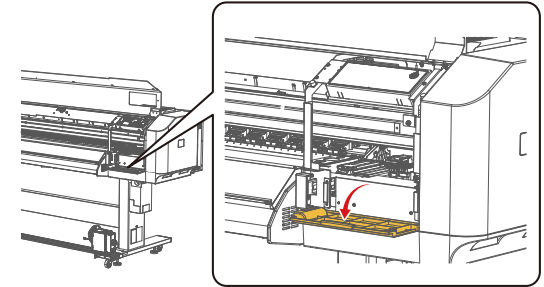

7 Fill the head cap with maintenance cleaner.

- Use a dropper to fill it with maintenance cleaner until the cleaner almost overflows the cap.

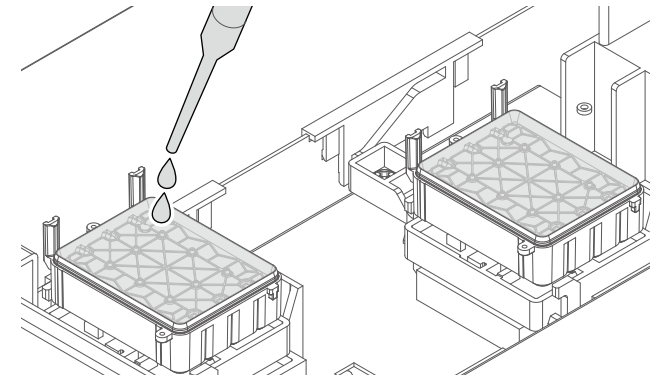

8 Using a paper towel, wipe off any ink on the surface of the air valve (parts ① and ②).

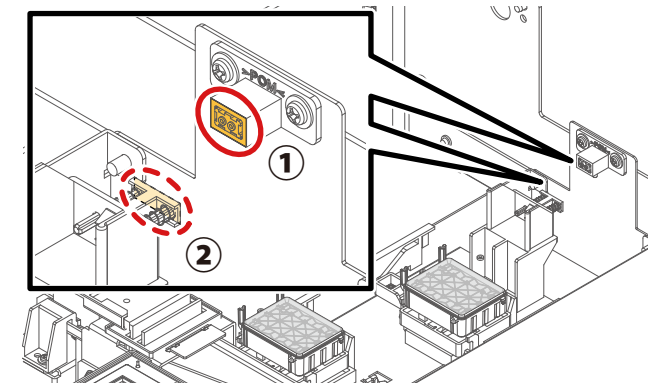

Before Use	Key operation
Basic Operations	Menu 1: Setup menus
Various settings	Menu 2: Test Print
Maintenance	Menu 3: Cleaning
When problems occur	Menu 4: Menu Option
Appendix	Menu 5: System Info.
	Menu 6: Sleep mode
	Menu 7: Initial Settings
	Menu 8: Job status
	Menu 9: Roll Length Manage
	Menu 10: Media Adjustment
	Menu 11: CR Maintenance
	Menu 12: Soak Cleaning

9 Close the front cover.

10 Tap  ([Enter] key).

- The countdown begins (count by minutes). When the timer reaches 1 minute left, it will count by seconds.
- When the timer reaches 0, the cleaning begins automatically.

Soaking time	
(1-99)	10 min

11 End the soak cleaning.

- Wipe the maintenance cleaner on the dropper with a paper towel.

Important!

- Please keep the bottle lid of the designated maintenance cleaner tightly closed.

Maintenance

About Maintenance	129
Wearing protective equipment	132
Checking ink and replacing ink bag	133
Emptying waste ink tank	138
Daily maintenance at the end of work	141
Printer maintenance	152
Replace the consumable parts	157
Moving or transporting the printer	172
Long-term storage	175

Before Use

Basic Operations

Various settings

Maintenance

When problems occur

Appendix

About Maintenance

Wearing protective equipment

Checking ink and replacing ink bag

Emptying waste ink tank

Daily maintenance at the end of work

Printer maintenance

Replace the consumable parts

Moving or transporting the printer

Long-term storage

About Maintenance

To maintain your printer performance, please conduct the following maintenance.

■ When to perform maintenance

Timing	Item
Before daily operation	"Nozzle check and head cleaning" P.61
After daily operation	"Daily maintenance at the end of work" P.141
When needed	"Replace the ink bag" P.134
	"Emptying waste ink tank" P.138
	"Clean the parts around the print head" P.146
	<ul style="list-style-type: none">When clogged nozzles or blurred or missing prints do not disappear after head cleaning.When printing is partially stained.
	Cleaning Wipers
	<ul style="list-style-type: none">When clogged nozzles or blurred or missing prints do not disappear after head cleaning.
	 "Clean the cleaning wiper and the parts around the capping unit" P.147
	"Menu 12: Soak Cleaning" P.125
	<ul style="list-style-type: none">When clogged nozzles or blurred or missing prints do not disappear after head cleaning
	"Clean the color sensor" P.153
<ul style="list-style-type: none">When auto adjustment fails repeatedly in "Print quality calibration (Adjust Print)" and "Adjust Head".	
"Replace the wiper pad" P.160	
<ul style="list-style-type: none">When ink has accumulated on absorbent material.	
"Replace the Cutter" P.163	
<ul style="list-style-type: none">When the media cannot be cut straight or fluffing occurs at the cut section.	
"Replace the UV-LED unit glass" P.168	
<ul style="list-style-type: none">When the glass is defective or stains are not removed.	
"Replace the flushing box" P.170	
<ul style="list-style-type: none">When the ink accumulated on the flushing box	

Before Use	About Maintenance
Basic Operations	Wearing protective equipment
Various settings	Checking ink and replacing ink bag
Maintenance	Emptying waste ink tank
When problems occur	Daily maintenance at the end of work
Appendix	Printer maintenance
	Replace the consumable parts
	Moving or transporting the printer
	Long-term storage

Once a week	"Menu 12: Soak Cleaning" P.125
Once a month	"Replace the UV-LED unit filter" P.166 <ul style="list-style-type: none"> • If the filter is significantly dirty, do not wait one month before replacing.
	"Cleaning inside the printer" P.155
	<ul style="list-style-type: none"> • If it is significantly dirty, do not wait one month before cleaning.
Once a year	"Cleaning Wiper" P.157
When not used for a week or more	"Nozzle check and head cleaning" P.152
When not used for a long period	"Long-term storage" P.175

Before Use

Basic Operations

Various settings

Maintenance

When problems occur

Appendix

About Maintenance

Wearing protective equipment

Checking ink and replacing ink bag

Emptying waste ink tank

Daily maintenance at the end of work

Printer maintenance











Replace the consumable parts

Moving or transporting the printer

Long-term storage

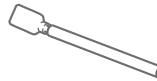
Preparations for maintenance

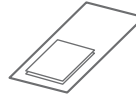
Prepare the following items for maintenance.

 Polyethylene gloves	 Rubber gloves	 Protective goggles	 Protective mask	 Protective clothing
 Designated maintenance cleaner	 Cleaning stick	 Plastic cup	 Dropper	 Paper towel or polyknit wipers
 Tray				

Important!

- Please use the paper towels supplied with the product or the optional poly-knit wiper.
- Do not use tissue paper. Lint or flakes on tissue may cause the print head to malfunction.
- Do not use non-designated maintenance cleaner.
- To purchase the optional accessories such as designated maintenance cleaner, contact your local MUTOH dealer.

Before Use

About Maintenance

Basic Operations

Wearing protective equipment

Various settings

Checking ink and replacing ink bag

Maintenance

Emptying waste ink tank

When problems occur

Daily maintenance at the end of work

Appendix

Printer maintenance

Replace the consumable parts

Moving or transporting the printer

Long-term storage

Wearing protective equipment

Wear protective equipment such as supplied gloves (or solvent-resistant gloves) and protective goggles, especially when performing the following maintenance

- "Checking ink and replacing ink bag" P.133
- "Emptying waste ink tank" P.138
- "Daily maintenance at the end of work" P.141
- "Menu 12: Soak Cleaning" P.125
- "Clean the color sensor" P.153
- "Cleaning inside the printer" P.155
- "Replace the flushing box" P.170
- "Cleaning Wiper" P.157
- "Replace the wiper pad" P.160
- "Replace the UV-LED unit filter" P.166
- "Replace the UV-LED unit glass" P.168

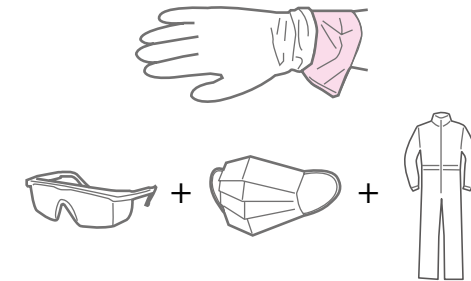

Before starting maintenance, please read the following sections:

- ☞ "Handling" P.10
- ☞ "Ink and waste fluid" P.15

Wearing the supplied gloves

Wear the rubber gloves over the polyethylene gloves (pink).



Before Use

About Maintenance

Basic Operations

Wearing protective equipment

Various settings

Checking ink and replacing ink bag

Maintenance

Emptying waste ink tank

When problems occur

Daily maintenance at the end of work

Appendix

Printer maintenance









Replace the consumable parts

Moving or transporting the printer

Long-term storage

Checking ink and replacing ink bag

Checking ink level

- 1** Access the "System Info." menu.
 1. Tap  ([Home] key). "Setup" will be displayed.
 2. Tap  /  key to display the "System Info.".
 3. Tap  key to display "Version".
- 2** Access the "Ink Status" menu.
 1. Tap  key to display "Version".
 2. Tap  /  key to display "Ink Status".
 3. Tap  ([Enter] key).
- 3** The ink level of each ink bag is displayed in percentage (0% to 100%).

KCMY : 100 / 90 / 90 / 80

C: Cyan, M: Magenta, Y: Yellow, K: Black

Note

If the remaining ink level is blinking at 10%, Smartchip recovery is being performed for the corresponding ink bag.

 ["Smartchip Recovery" P.189](#)

Before Use

About Maintenance

Basic Operations

Wearing protective equipment

Various settings

Checking ink and replacing ink bag

Maintenance

Emptying waste ink tank

When problems occur

Daily maintenance at the end of work

Appendix

Printer maintenance

Replace the consumable parts

Moving or transporting the printer

Long-term storage

When an ink bag is nearing replacement

When the ink level is low, the status light on the printer control panel blinks in red with beep sound.

- 1 Tap  ([Enter] key).
 - The beep sound stops.
 - In this figure,, the black ink is nearing replacement.

[K] S/C Ink Low

PG : Low

W : 1625 mm

- 2 Replace with a new ink bag.
 ["Replace the ink bag" P.134](#)

Replace the ink bag

When an ink bag runs out of ink, the status light on the printer control panel turns on red with beep sound. "Ink End" or "S/C Ink End" will appear on the printer control panel. Promptly replace it with a new ink bag and smart-chip card. If ink is not replaced for a certain period of time, printing will pause. In this case, replace the ink bag with a new one and printing will resume.



Caution



Be careful not to get ink in your eyes or on your skin. Wear gloves, protective glasses, and a mask. If in eyes or on skin, immediately flush with water. If left untreated, it may cause redness and mild irritation of the eye. In case of any abnormality, consult a physician immediately.

Important!!

- If the printer is powered off, do not replace with a new ink bag. The printer may not be able to detect ink level correctly.
- When moving an ink bag from cold place to warm place, rest it in room temperature at least 3 hours before use.
- If you do not have a new ink bag for replacement, leave the old one installed. Leaving the printer without ink bags installed could cause nozzle clogging.

Remove the ink bag case

- 1 Tap  ([Enter] key).
 - The beep sound stops.
 - In this figure, the black ink needs to be replaced.

[KCMY] Ink End

- 2 Remove the ink bag case of the ink bag to be replaced and the corresponding smartchip card.

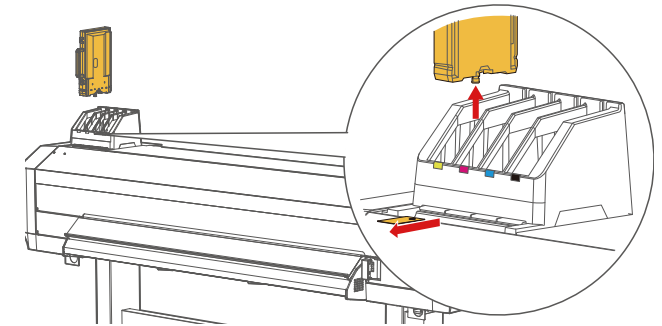

- 3 Unlock the four latches on the ink bag case and open the ink bag case.

Important!!

Do not apply excessive force when unlocking. This may cause damage to the latch.

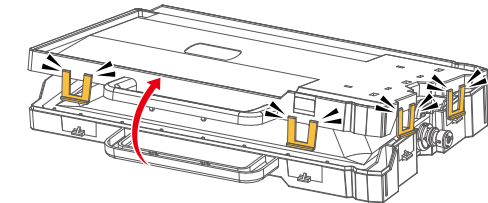

- 4 Remove the empty ink bag.

Note

Put the empty ink bag in a plastic bag and dispose of it according to the local regulations.

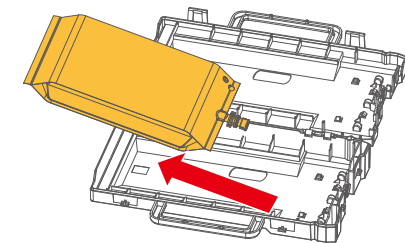

Before Use

About Maintenance

Basic Operations

Wearing protective equipment

Various settings

Checking ink and replacing ink bag

Maintenance

Emptying waste ink tank

When problems occur

Daily maintenance at the end of work

Appendix

Printer maintenance

Replace the consumable parts

Moving or transporting the printer

Long-term storage

Load a new ink bag

- 1 Agitate the ink in the ink bag.
 1. Hold the ink bag with the ink outlet facing up and wait for 3 seconds.
 2. Invert it so that the ink outlet is facing down and wait for 3 seconds.
 3. Repeat this 3 times.

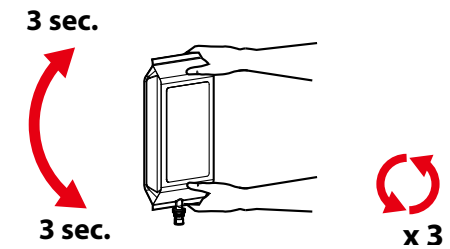

- 2 Put the ink bag into the ink bag case.

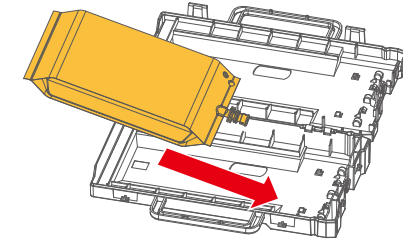

- 3 Close the ink bag case.
 - Make sure that the spout of the ink bag is properly fitted into the groove in the case..

Important!

If not fitted, the printer cannot correctly detect the ink bag.

- Close the latches (x 4) of the case properly.

Important!

If not secured, it may cause ink leakage.

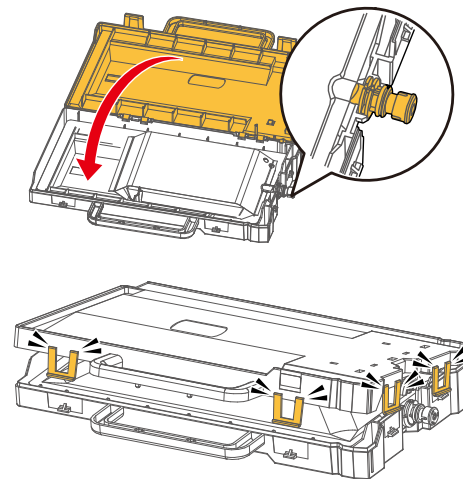

Before Use

About Maintenance

Basic Operations

Wearing protective equipment

Various settings

Checking ink and replacing ink bag

Maintenance

Emptying waste ink tank

When problems occur

Daily maintenance at the end of work

Appendix

Printer maintenance

Replace the consumable parts

Moving or transporting the printer

Long-term storage

4 Insert the ink bag case and smartchip card into an appropriate slot.

- Make sure to match the color of the ink bag label with the color of the label attached to the ink slot.
 1. Face the latch side towards you and insert the case into the slot.
 2. Make sure that they are fully inserted.

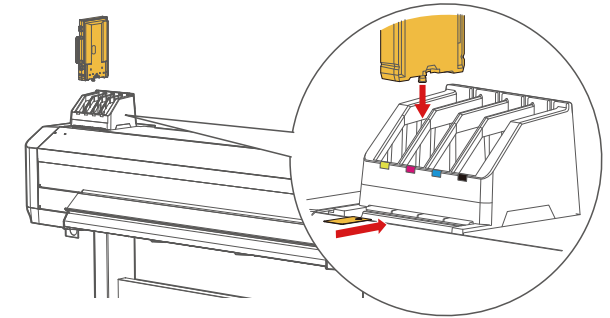

Before Use

About Maintenance

Basic Operations

Wearing protective equipment

Various settings

Checking ink and replacing ink bag

Maintenance

Emptying waste ink tank

When problems occur

Daily maintenance at the end of work

Appendix

Printer maintenance

Replace the consumable parts

Moving or transporting the printer

Long-term storage

Emptying waste ink tank

In the following cases, drain waste fluids into a container to empty the waste ink tank:

- When the waste ink tank is more than half full.
- When the message [Empty Waste Ink Tank then Tap Enter] appears. (P.184) .
- When the message [Full WasteInkTank] appears. (P.187)



WARNING



- Store waste fluids in a cool, dark place and avoid direct sunlight.
- Keep away from fire and heat.



- Do not mix waste ink with any other chemical substances or liquid, not even in small amounts.
- Mixing with other chemical substances (e.g. oxidizing agent) could cause heat.
- Use a HDPE container with light blocking properties to store waste fluid.
- When storing waste fluid for a long time, slightly loosen the cap on the container to allow air. Do not tightly close it.



Caution



- Skin or eye contact with UV curable ink may cause skin inflammation or allergic reaction.
- When emptying the tank, be sure to wear the gloves (or solvent-resistant gloves) and protective goggles provided, and take care not to get ink on them.

1

Prepare a container to collect waste liquid.

Important!

The capacity of the waste ink tank is 2,000 ml. Make sure to prepare a container that has enough capacity.

2

Cover the floor under the waste ink tank with waste paper or cloth.

Before Use

About Maintenance

Basic Operations

Wearing protective equipment

Various settings

Checking ink and replacing ink bag

Maintenance

Emptying waste ink tank

When problems occur

Daily maintenance at the end of work

Appendix

Printer maintenance

Replace the consumable parts

Moving or transporting the printer

Long-term storage

3 Wear protective equipment.
☞ "Preparations for maintenance" P.131,

1. Wear rubber gloves over polyethylene gloves.
2. Wear protective goggles.

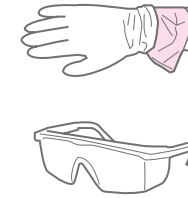

4 Open the cover of the waste ink valve case, and then take the drain tube valve out from the case.

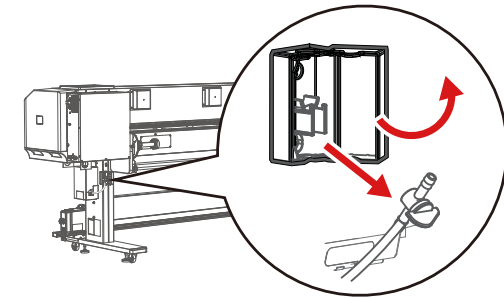

5 Put the tip of the drain tube valve in the container and open the valve to drain waste ink from the waste ink tank.

Important!

Waste ink may splash while draining from the waste ink tank. Make sure to put the tip of the drain tube valve in the empty container to drain.

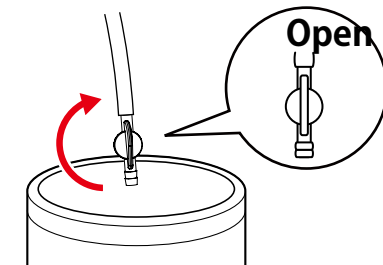

6 Once you finish emptying the tank, close the drain tube valve firmly.

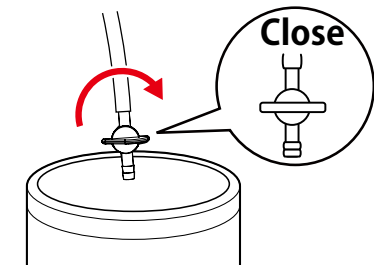

Before Use

About Maintenance

Basic Operations

Wearing protective equipment

Various settings

Checking ink and replacing ink bag

Maintenance

Emptying waste ink tank

When problems occur

Daily maintenance at the end of work

Appendix

Printer maintenance

Replace the consumable parts

Moving or transporting the printer

Long-term storage

7 Use a dry cloth to clean the tip of the valve.

8 Hook the drain tube valve on the clamp of the waste ink valve case, then close the cover.

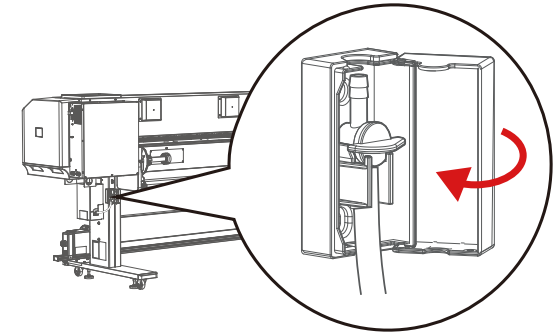

9 Dispose of the waste fluids as industrial waste.



WARNING



- Waste liquids fall under the category of waste oil (waste ink) in industrial waste. You are obligated to properly dispose of waste fluid from the printer in compliance with Wastes Disposal and Public Cleansing Act and local ordinances. Delegate disposal to an industrial waste disposal contractor.
- Waste fluid from this printer is harmful to aquatic organisms. Do not allow it to reach sewage or natural water systems.

Before Use

About Maintenance

Basic Operations

Wearing protective equipment

Various settings

Checking ink and replacing ink bag

Maintenance

Emptying waste ink tank

When problems occur

Daily maintenance at the end of work

Appendix

Printer maintenance

Replace the consumable parts

Moving or transporting the printer

Long-term storage

Daily maintenance at the end of work

Printers require daily maintenance. Follow these steps to perform a daily maintenance when you are done printing for the day



Make sure to read the following sections before this task.

👉 "Handling" P.10

👉 "Ink and waste fluid" P.15

Important!

Make sure to perform daily maintenance once a day. Failure to perform maintenance may result in poor image quality or malfunction.

Preparations for maintenance P.131

1. Clean the UV-LED unit P.143

2. Moisten the surface of print head nozzles P.144

3. Clean the parts around the print head P.146

4. Clean the cleaning wiper and the parts around the capping unit P.147

5. Fill maintenance cleaner P.149

6. End the maintenance P.151

Before Use

Basic Operations

Various settings

Maintenance

When problems occur

Appendix

About Maintenance

Wearing protective equipment

Checking ink and replacing ink bag

Emptying waste ink tank

Daily maintenance at the end of work

Printer maintenance

Replace the consumable parts

Moving or transporting the printer

Long-term storage

Preparation

1

Wear protective equipment.

 ["Preparations for maintenance" P.131](#)

1. Wear rubber gloves over polyethylene gloves.
2. Wear protective equipment such as protective goggles, protective masks, protective clothing, etc.

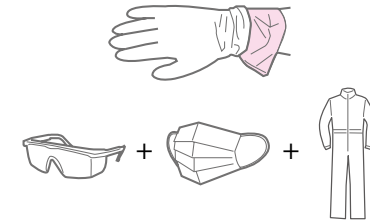

2

Put the printer into CR maintenance state (or turn off the printer).

 ["Menu 11: CR Maintenance" P.123](#)

 ["Turn off the printer" P.44](#)

Procedure

 **Caution**



The UV-LED lamp may get hot after printing.

Allow the lamp to cool down for at least 10 minutes after printing and then start this task.

 **Note**

Standard cleaning time is within 5 minutes. If more than 10 minutes have passed since the cover was opened the message "Close the Cover" will appear with beep sound.

Before Use

About Maintenance

Basic Operations

Wearing protective equipment

Various settings

Checking ink and replacing ink bag

Maintenance

Emptying waste ink tank

When problems occur

Daily maintenance at the end of work

Appendix

Printer maintenance

Replace the consumable parts

Moving or transporting the printer

Long-term storage

1. Clean the UV-LED unit

1 Open the front cover.

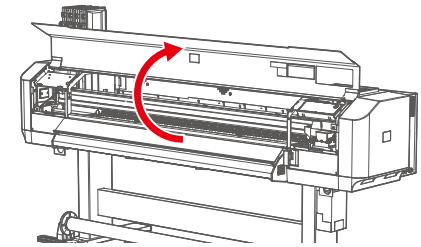

2 Open the left maintenance cover.

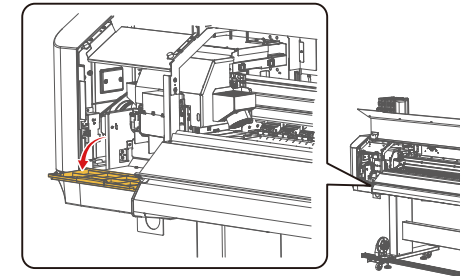

3 Look at the bottom surface of the UV-LED lamp and wipe off any sticking ink or dust with a paper towel.

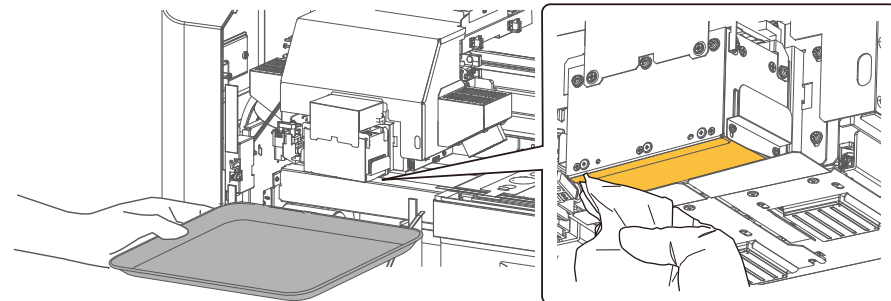

4 Next, moisten the nozzle surface of the print head.
☞ "2. Moisten the surface of print head nozzles" P.144

Before Use

About Maintenance

Basic Operations

Wearing protective equipment

Various settings

Checking ink and replacing ink bag

Maintenance

Emptying waste ink tank

When problems occur

Daily maintenance at the end of work

Appendix

Printer maintenance

Replace the consumable parts

Moving or transporting the printer

Long-term storage

2. Moisten the surface of print head nozzles

Important!

- Be sure to follow the cleaning procedure as instructed. In particular, do not moisten the nozzle surface with the same cleaning stick that is used to clean the print head area, cleaning wiper, or capping unit. This may cause print head failure.
- Be sure to use a new cleaning stick and the designated maintenance cleaner. Use of non-designated one may cause the print head failure.
- Do not touch the tip of the cleaning stick with your finger. If skin oil gets on the stick, it may cause the print head to malfunction.

- 1 Put a new cleaning stick in the plastic cup. Use the dropper to drop the designated maintenance cleaner onto the tip of the cleaning stick to moisten (Use about 5 ml).



- 2 Look at the bottom surface of the carriage and moisten the nozzle surface of the print head with the cleaning stick dampened with the maintenance cleaner.
 - Lightly touch with the cleaning stick.
 - Repeat several times until the entire surface of the nozzle is moistened.

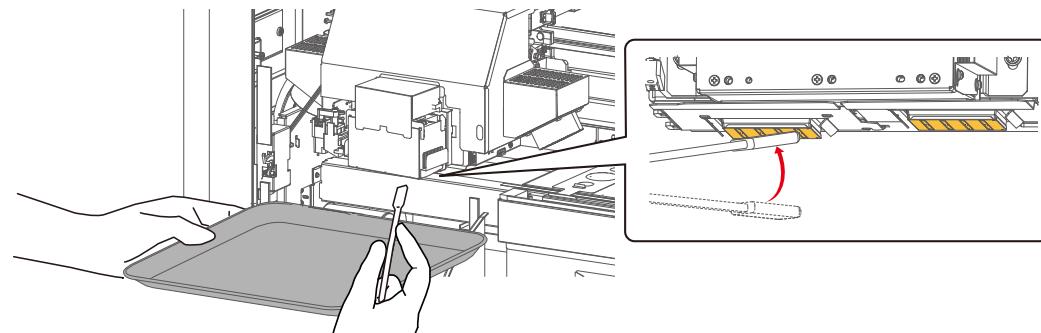

Important!

- Never rub the surface of the nozzles. This may cause print head failure.
- When the entire nozzle surface has been moistened, you can stop it. Do not repeat more than necessary.

Before Use	About Maintenance
Basic Operations	Wearing protective equipment
Various settings	Checking ink and replacing ink bag
Maintenance	Emptying waste ink tank
When problems occur	Daily maintenance at the end of work
Appendix	Printer maintenance
	Replace the consumable parts
	Moving or transporting the printer
	Long-term storage

3 Next, clean the parts around the print head.
 ["3. Clean the parts around the print head" P.146](#)

Before Use

About Maintenance

Basic Operations

Wearing protective equipment

Various settings

Checking ink and replacing ink bag

Maintenance

Emptying waste ink tank

When problems occur

Daily maintenance at the end of work

Appendix

Printer maintenance

Replace the consumable parts

Moving or transporting the printer

Long-term storage

3. Clean the parts around the print head

1 Clean the bottom surface of the carriage and the side surface of the print heads.

 : Cleaning area.

 : Never touch the nozzle surface.

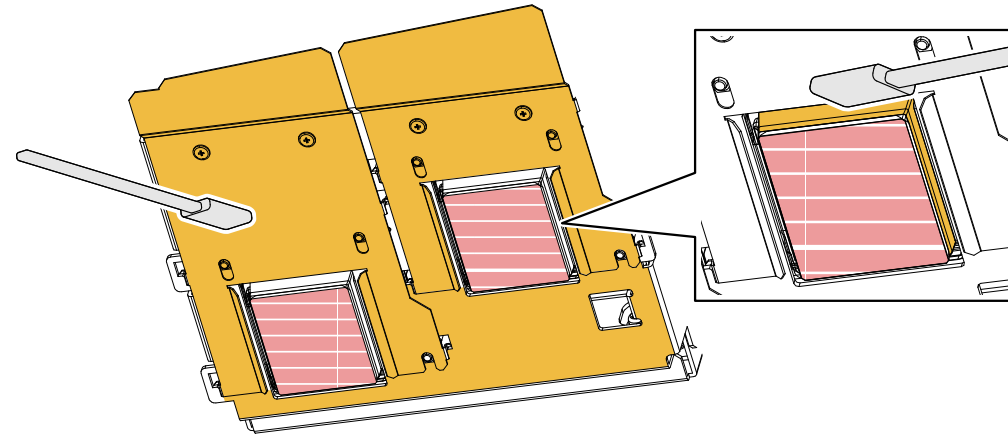

Important!

If the maintenance fluid gets on the printer, wipe it off with a paper towel.

2 Next, clean the cleaning wiper and the parts around the capping unit.

 "4. Clean the cleaning wiper and the parts around the capping unit" P.147

Important!

- If the cleaning stick becomes dirty during cleaning, put the maintenance cleaner in the plastic cup and submerge the foam tip of the stick into the maintenance cleaner in the cup to clean it. If the dirt does not get off, replace it with a new one.

Before Use

About Maintenance

Basic Operations

Wearing protective equipment

Various settings

Checking ink and replacing ink bag

Maintenance

Emptying waste ink tank

When problems occur

Daily maintenance at the end of work

Appendix

Printer maintenance

Replace the consumable parts

Moving or transporting the printer

Long-term storage

4. Clean the cleaning wiper and the parts around the capping unit

- 1 Open the right side maintenance cover.

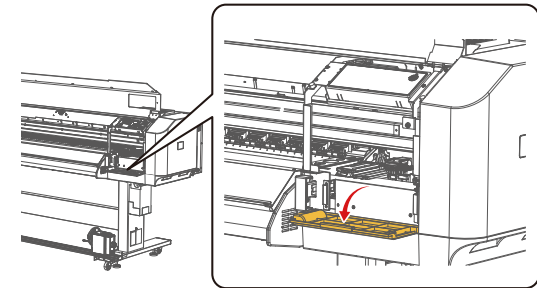

- 2 Use the cleaning stick to wipe off any dirt on the front side of the cleaning wiper.

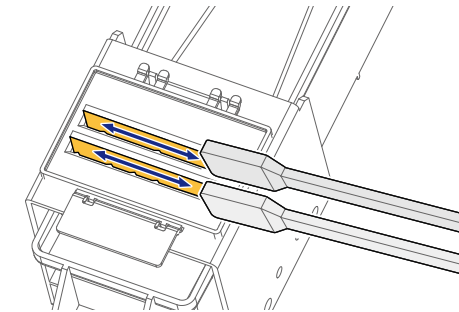

- 3 Wipe off the dirt on the back side of the cleaning wiper.

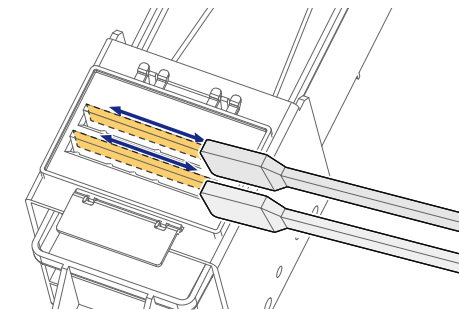

Before Use

About Maintenance

Basic Operations

Wearing protective equipment

Various settings

Checking ink and replacing ink bag

Maintenance

Emptying waste ink tank

When problems occur

Daily maintenance at the end of work

Appendix

Printer maintenance

Replace the consumable parts

Moving or transporting the printer

Long-term storage

4 Wipe off the dirt on the top of the cleaning wiper.

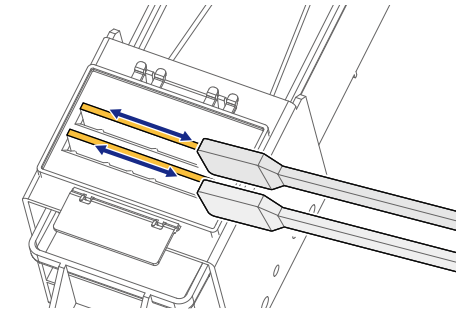

5 Use the cleaning stick to clean the parts around the capping unit to wipe off ink and dust.

 Cleaning area  Do not touch the absorbent material.

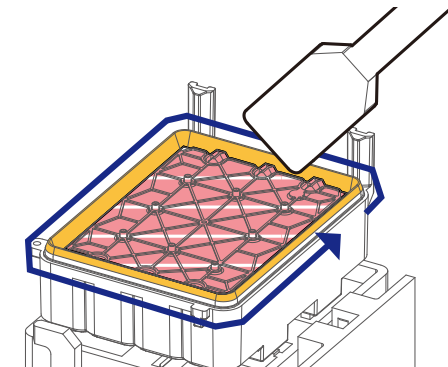

6 Next, fill maintenance cleaner.
 "5. Fill maintenance cleaner" P.149

Before Use

About Maintenance

Basic Operations

Wearing protective equipment

Various settings

Checking ink and replacing ink bag

Maintenance

Emptying waste ink tank

When problems occur

Daily maintenance at the end of work

Appendix

Printer maintenance

Replace the consumable parts

Moving or transporting the printer

Long-term storage

5. Fill maintenance cleaner

- 1 Fill the wiper pad with maintenance cleaner.
 - Drop maintenance cleaner until the entire pad is wet and dripping in the tray under the pad (Use about 10 ml).

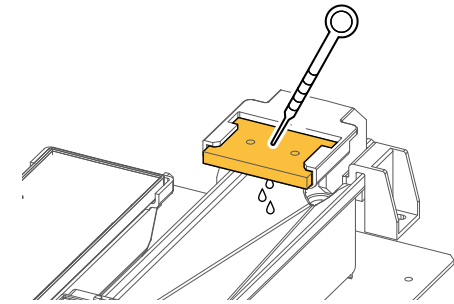

- 2 Fill 30 ml of maintenance cleaner into the flushing box.

Important!

If the maintenance cleaner is spilled on the cover of the flushing box, clean it with a paper towel to avoid splash by a fan.

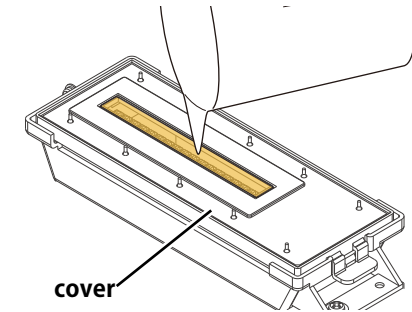

- 3 Close the left and right maintenance covers.

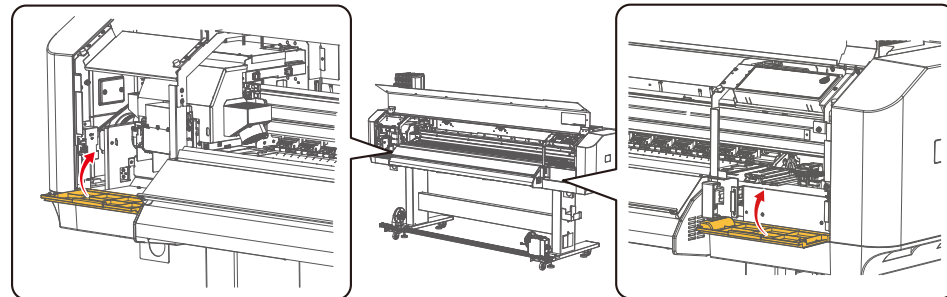

Before Use	About Maintenance
Basic Operations	Wearing protective equipment
Various settings	Checking ink and replacing ink bag
Maintenance	Emptying waste ink tank
When problems occur	Daily maintenance at the end of work
Appendix	Printer maintenance
	Replace the consumable parts
	Moving or transporting the printer
	Long-term storage

4 Close the front cover.

5 Next, end the maintenance.
 ["6. End the maintenance" P.151](#)

Before Use	About Maintenance
Basic Operations	Wearing protective equipment
Various settings	Checking ink and replacing ink bag
Maintenance	Emptying waste ink tank
When problems occur	Daily maintenance at the end of work
Appendix	Printer maintenance
	Replace the consumable parts
	Moving or transporting the printer
	Long-term storage

6. End the maintenance

1 Tap  ([Enter] key) to exit maintenance.

 "Menu 11: CR Maintenance" P.123

 "Turn off the printer" P.44

- The carriage moves to the CR maintenance position on the right side.

Note

- After 30 seconds of closing the cover, maintenance is automatically terminated.

- When performed maintenance from [CR Maintenance]

```
CR Maintenance
End      ->   Enter
```

- When performed maintenance from [Turn off the printer]

```
Daily Maintenance
End      ->   Enter
```

2 • Dispose of cleaning stick .

- Wipe the maintenance cleaner on the dropper with a paper towel.
- Dispose of the maintenance cleaner in the plastic cup and wipe the plastic cup clean with a paper towel.
- Wipe the tray with paper towels.

Important!

- Do not reuse the cleaning stick . Dust and other particles may adhere to the print head, causing it to malfunction.
- Please keep the bottle lid of the designated maintenance cleaner tightly closed.

Note

- Used cleaning stick and the maintenance cleaner left in the plastic cup are industrial waste. Dispose of them in accordance with the local regulations.

Before Use	About Maintenance
Basic Operations	Wearing protective equipment
Various settings	Checking ink and replacing ink bag
Maintenance	Emptying waste ink tank
When problems occur	Daily maintenance at the end of work
Appendix	Printer maintenance
	Replace the consumable parts
	Moving or transporting the printer
	Long-term storage

Printer maintenance

Nozzle check and head cleaning

If the nozzles are clogged after a nozzle check, head cleaning should be performed.

-  ["Performing Nozzle Check" P.61](#)





Run a nozzle check print to see if the print head fires ink properly.

-  ["Performing Head cleaning" P.63](#)

If the nozzle is clogged, perform a head cleaning. The product has several cleaning modes. Use it according to the print results of the nozzle check.

Note

If nozzle clogging persists after repeated Normal cleaning attempts, try the following solutions for a reference.

1. Perform a Long cleaning. (If the problem persists, move to the next one)
2. Clean the following parts. (If the problem persists, move to the next one)
 -  ["4. Clean the cleaning wiper and the parts around the capping unit" P.147](#)
 -  ["3. Clean the parts around the print head" P.146](#)
3. Perform a Little Charge cleaning. (If the problem still persists, move to the next one)
 -  ["Menu 3: Cleaning" P.111](#)
4. Perform a soak cleaning.
 -  ["Menu 12: Soak Cleaning" P.125](#)

Before Use	About Maintenance
Basic Operations	Wearing protective equipment
Various settings	Checking ink and replacing ink bag
Maintenance	Emptying waste ink tank
When problems occur	Daily maintenance at the end of work
Appendix	Printer maintenance
	Replace the consumable parts
	Moving or transporting the printer
	Long-term storage

Clean the color sensor

Important!!

- Do not push hard on the color sensor glass with cleaning stick. This will cause damage to the glass.
- Do not reuse the cleaning stick. This will cause dust to adhere to the sensor, leading to malfunction.
- The standard maintenance time is about five minutes. If it takes longer, the print head will get dried, causing the damage.

1 Prepare the necessary items for maintenance.

 ["Preparations for maintenance" P.131](#)

What you need:

- Polyethylene gloves, Rubber gloves, Protective goggles, Protective mask
- Cleaning stick
- Ethanol (more than 50% ethanol)

2 Wear protective equipment.

 ["Wearing protective equipment" P.132](#)

3 Put the printer into CR maintenance state.

 ["Menu 11: CR Maintenance" P.123](#)

4 Open the front cover.

Before Use

About Maintenance

Basic Operations

Wearing protective equipment

Various settings

Checking ink and replacing ink bag

Maintenance

Emptying waste ink tank

When problems occur

Daily maintenance at the end of work

Appendix

Printer maintenance

Replace the consumable parts

Moving or transporting the printer

Long-term storage

5 Open the left maintenance cover.

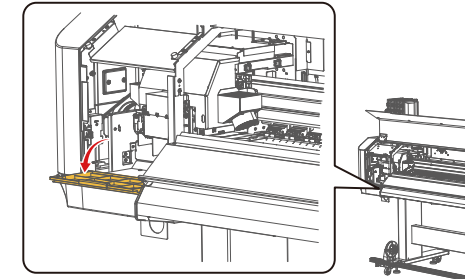

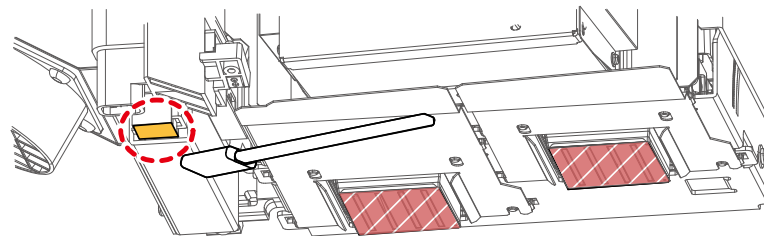

6 Gently clean the glass surface of the color sensor on the bottom of the carriage with a cleaning stick dampened in a small amount of ethanol to remove ink and dust.



 Cleaning area (do not push hard on glass surface)

 Never touch the head surface.

7 Close the maintenance cover and then the front cover.

8 Tap  ([Enter] key) to exit maintenance.
 "6. End the maintenance" P.151

 Note

Put the used cleaning stick in a cleaning bag and dispose of it according to the local regulations.

Before Use	About Maintenance
Basic Operations	Wearing protective equipment
Various settings	Checking ink and replacing ink bag
Maintenance	Emptying waste ink tank
When problems occur	Daily maintenance at the end of work
Appendix	Printer maintenance
	Replace the consumable parts
	Moving or transporting the printer
	Long-term storage

Cleaning inside the printer



Caution



When cleaning the inside of the printer, be sure to turn off the power and unplug the power plug from the power outlet.



Important!!

Immediately after printing is finished, the printer heater gets hot. Touch the platen or media guide, and if it is hot, wait until it is cool down.

1 Prepare the necessary items for maintenance.

 [Preparations for maintenance P.131](#)

What you need:

- Soft brush
- Paper towel or soft cloth
- Ethanol (more than 50% ethanol)
- Glove

2 Remove the media.

3 Make sure the printer is turned off.

4 Open the front cover.

Before Use

About Maintenance

Basic Operations

Wearing protective equipment

Various settings

Checking ink and replacing ink bag

Maintenance

Emptying waste ink tank

When problems occur

Daily maintenance at the end of work

Appendix

Printer maintenance

Replace the consumable parts

Moving or transporting the printer

Long-term storage

- 5 Use a soft brush to clean the dust off the pressure rollers.

Important!!

Do not use air duster to clean the dust inside the printer. This will cause dust to accumulate on the moving parts, leading to damage or noise.

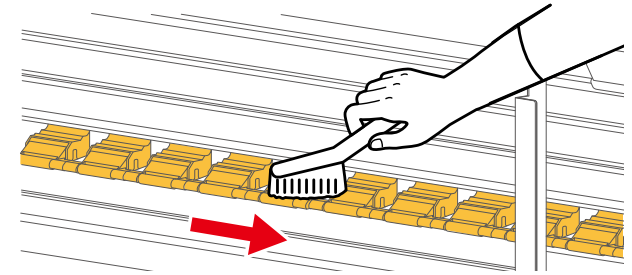

- 6 Using a paper towel or soft cloth dampened with in a small amount of ethanol, clean the platen, media guide and edge holders to remove dust.

Important!!

Wear gloves when cleaning.

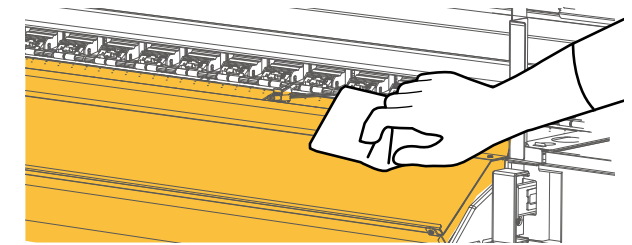

- 7 Close the front cover.

Before Use

About Maintenance

Basic Operations

Wearing protective equipment

Various settings

Checking ink and replacing ink bag

Maintenance

Emptying waste ink tank

When problems occur

Daily maintenance at the end of work

Appendix

Printer maintenance

Replace the consumable parts

Moving or transporting the printer

Long-term storage

Replace the consumable parts

Cleaning Wiper

The cleaning wiper is a necessary component for maintaining consistent printing quality. Replace it regularly.



Caution



Be careful not to get ink in your eyes or on your skin. Wear gloves, protective glasses, and a mask. In case of contact with eyes or skin, rinse immediately with water. If left untreated, it may cause redness and mild irritation of the eye. In case of any abnormality, consult a physician immediately.

1

Prepare the necessary items for maintenance.

 ["Preparations for maintenance" P.131](#)

What you need:

- Polyethylene gloves, Rubber gloves, Protective goggles, Protective mask
- Replacement cleaning wipers
- Waste paper (paper that ink does not bleed through)

2

Wear protective equipment.

 ["Wearing protective equipment" P.132](#)

3

Put the printer in CR maintenance state.

 ["Menu 11: CR Maintenance" P.123](#)

4

Open the front cover.

Before Use

About Maintenance

Basic Operations

Wearing protective equipment

Various settings

Checking ink and replacing ink bag

Maintenance

Emptying waste ink tank

When problems occur

Daily maintenance at the end of work

Printer maintenance

Appendix

Replace the consumable parts

Moving or transporting the printer

Long-term storage

- 5 Open the right side maintenance cover.

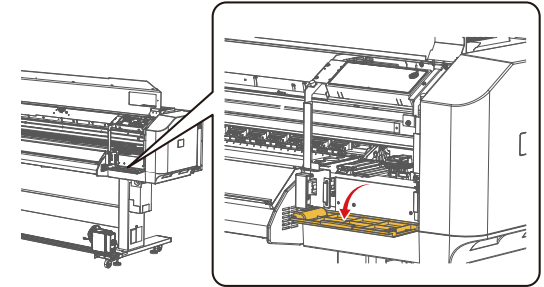

- 6 Cover the platen with the waste paper.

Important!!

Ink may drip from the cleaning wiper. We recommend covering the floor with paper as well.

- 7 Remove the cleaning wipers.

1. Push the tab of the cleaning wiper to the back to release the hook in the front.
2. Remove the cleaning wiper by lifting up the tab of the cleaning wiper.

Important!!

- Wear gloves when cleaning.
- When removing the cleaning wiper, be careful of ink dripping.

Note

Put the used pad in a plastic bag and dispose of it according to the local regulations.

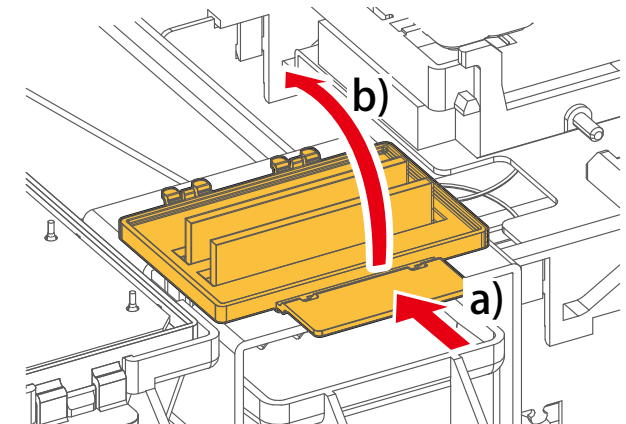

Before Use

About Maintenance

Basic Operations

Wearing protective equipment

Various settings

Checking ink and replacing ink bag

Maintenance

Emptying waste ink tank

When problems occur

Daily maintenance at the end of work

Appendix

Printer maintenance

Replace the consumable parts

Moving or transporting the printer

Long-term storage

8 Install a new cleaning wiper.

1. Insert the back of the cleaning wiper.
2. Push in the tab of the cleaning wiper until it clicks into place.

Important!!

Be careful not to touch the rubber part of the cleaning wiper with bare hands. Sebum can cause print head failure.

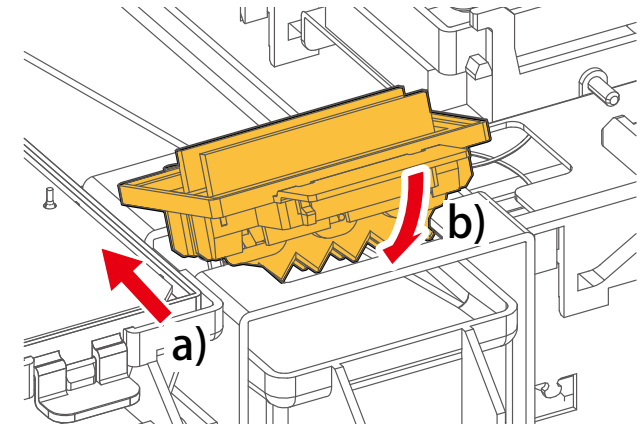

9 Close the maintenance cover and then the front cover.

10 Tap ([Enter] key) to exit maintenance.

 "6. End the maintenance" P.151

Before Use

About Maintenance

Basic Operations

Wearing protective equipment

Various settings

Checking ink and replacing ink bag

Maintenance

Emptying waste ink tank

When problems occur

Daily maintenance at the end of work

Appendix

Printer maintenance

Replace the consumable parts

Moving or transporting the printer

Long-term storage

Replace the wiper pad

Wiper pad is used to keep cleaning wipers clean. Ink sticking to the wiper can cause poor print quality. Replace it as needed.





Caution



Be careful not to get ink in your eyes or on your skin. Wear gloves, protective glasses, and a mask. In case of contact with eyes or skin, rinse immediately with water. If left untreated, it may cause redness and mild irritation of the eye. In case of any abnormality, consult a physician immediately.

Replacement procedure

- 1** Prepare the necessary items for maintenance.
 ["Preparations for maintenance" P.131](#)
What you need:
 - Polyethylene gloves, Rubber gloves, Protective goggles, Protective mask
 - Replacement wiper pad
- 2** Wear protective equipment.
 ["Wearing protective equipment" P.132](#)
- 3** Put the printer in CR maintenance state.
 ["Menu 11: CR Maintenance" P.123](#)
- 4** Open the front cover.

Before Use

About Maintenance

Basic Operations

Wearing protective equipment

Various settings

Checking ink and replacing ink bag

Maintenance

Emptying waste ink tank

When problems occur

Daily maintenance at the end of work

Appendix

Printer maintenance

Replace the consumable parts

Moving or transporting the printer

Long-term storage

5 Open the right side maintenance cover.

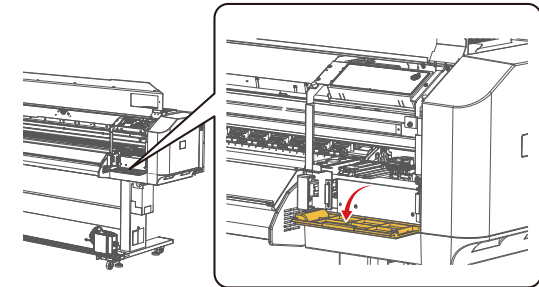

6 Pinch the wiper pad and lift it up to remove it.

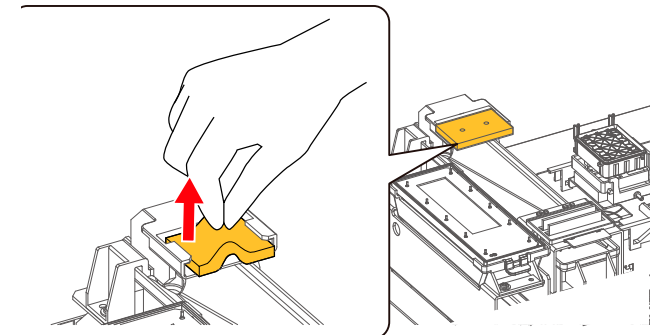

7 Insert the wiper pad into the pad slot from the top.

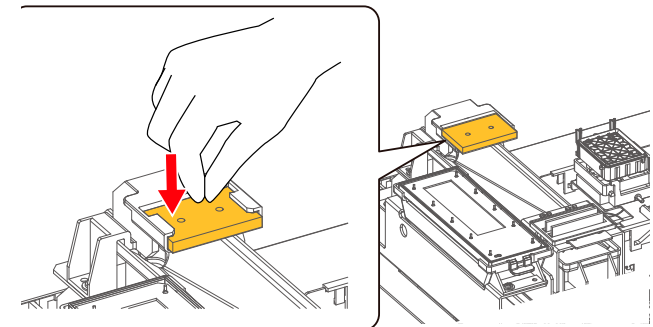

Before Use

About Maintenance

Basic Operations

Wearing protective equipment

Various settings

Checking ink and replacing ink bag

Maintenance

Emptying waste ink tank

When problems occur

Daily maintenance at the end of work

Appendix

Printer maintenance

Replace the consumable parts

Moving or transporting the printer

Long-term storage

8 Fill the wiper pad with maintenance cleaner.

- Drop maintenance cleaner until the entire pad is wet and dripping in the tray under the pad (Use about 10 ml).

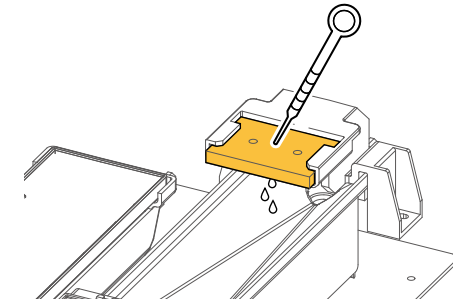

9 Close the maintenance cover and then the front cover.

10 Tap  ([Enter] key) to exit maintenance.

-  ["6. End the maintenance" P.151](#)

Before Use

About Maintenance

Basic Operations

Wearing protective equipment

Various settings

Checking ink and replacing ink bag

Maintenance

Emptying waste ink tank

When problems occur

Daily maintenance at the end of work

Appendix

Printer maintenance

Replace the consumable parts

Moving or transporting the printer

Long-term storage

Replace the Cutter



Caution



- Do not push the tab on the cutter holder too hard or release suddenly. There is a spring under the cutter so that the cutter may jump out from the holder.
- Do not touch the cutter blade. There is a risk of injury.

Replacement procedure

- 1 Prepare the necessary items for maintenance.
☞ ["Preparations for maintenance" P.131](#)

What you need:

- Cutter replacement blade

- 2 Put the printer in CR maintenance state.
☞ ["Menu 11: CR Maintenance" P.123](#)

- 3 Open the front cover.

- 4 Open the left maintenance cover.

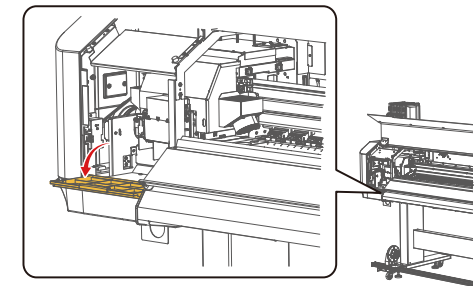

Before Use

About Maintenance

Basic Operations

Wearing protective equipment

Various settings

Checking ink and replacing ink bag

Maintenance

Emptying waste ink tank

When problems occur

Daily maintenance at the end of work

Appendix

Printer maintenance

Replace the consumable parts

Moving or transporting the printer

Long-term storage

- 5 While lightly pushing the tab on the cutter, rotate the cutter cap in the direction shown in the illustration.

Important!!

Do not push down the cutter cap.
It may damage the part.

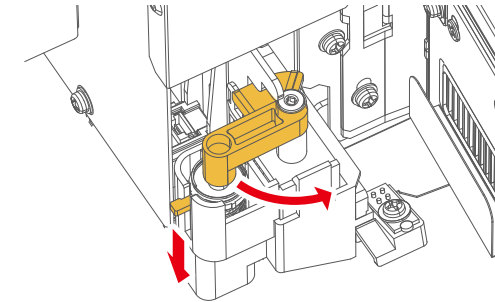

- 6 Remove the cutter.

Note

Put the used cutter in a plastic bag and dispose of it according to the local regulations.

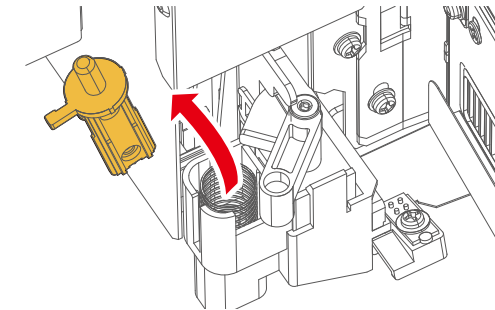

- 7 Attach a new cutter.

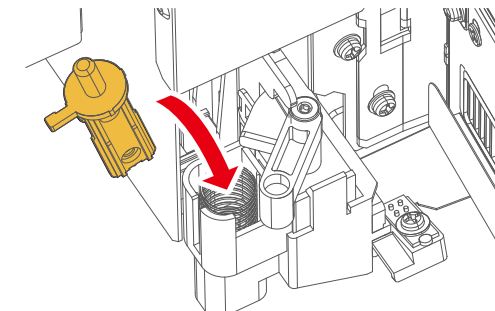

Before Use

About Maintenance

Basic Operations

Wearing protective equipment

Various settings

Checking ink and replacing ink bag

Maintenance

Emptying waste ink tank

When problems occur

Daily maintenance at the end of work

Appendix

Printer maintenance

Replace the consumable parts



Moving or transporting the printer

Long-term storage

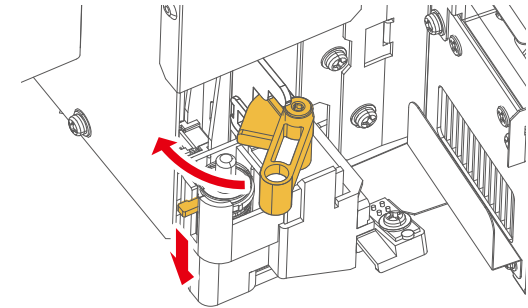
- 8 While lightly pushing the tab on the cutter, put the cutter cap back to its original position.



- 9 Close the maintenance cover and then the front cover.

- 10 Tap  ([Enter] key) to exit maintenance.
 "6. End the maintenance" P.151

Before Use

About Maintenance

Basic Operations

Wearing protective equipment

Various settings

Checking ink and replacing ink bag

Maintenance

Emptying waste ink tank

When problems occur

Daily maintenance at the end of work

Appendix

Printer maintenance

Replace the consumable parts

Moving or transporting the printer

Long-term storage

Replace the UV-LED unit filter

The UV-LED lamp filter protects the lamp from ink mist. Using a dirty filter will cause damage to the lamp. Make sure you replace it regularly.



Caution



Wear the protective gloves, glasses and masks and avoid contact with your eyes or skin. Eye or skin contact may cause slight irritation or bloodshot eyes. If in eyes or on skin, immediately flush with water. If irritation is present, seek medical advice/attention immediately.



The UV-LED lamp may get hot after printing. Allow the lamp to cool down for 10 minutes after printing and then start replacement.

Replacement procedure

1

Prepare the necessary items for maintenance.

 ["Preparations for maintenance" P.131](#)

What you need:

- Polyethylene gloves, Rubber gloves, Protective goggles, Protective mask
- Replacement Filters

2

Wear protective equipment.

 ["Wearing protective equipment" P.132](#)

3

Put the printer in CR maintenance state.

 ["Menu 11: CR Maintenance" P.123](#)

4

Open the front cover.

Before Use

Basic Operations

Various settings

Maintenance

When problems occur

Appendix

About Maintenance

Wearing protective equipment

Checking ink and replacing ink bag

Emptying waste ink tank

Daily maintenance at the end of work

Printer maintenance

Replace the consumable parts

Moving or transporting the printer

Long-term storage

5 Open the left maintenance cover.

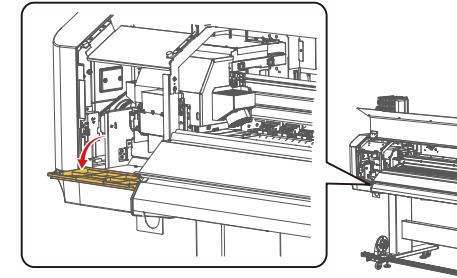

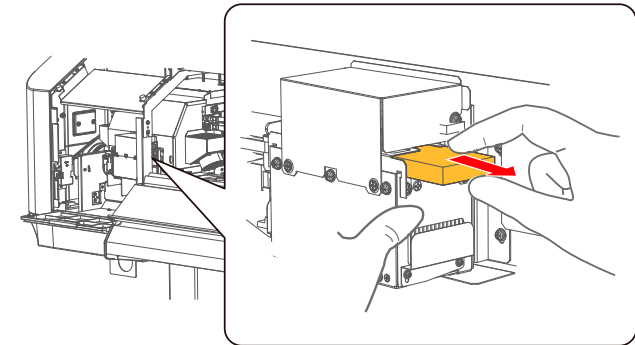

6 While holding the UV-LED unit, remove the filter.



7 Replace with a new filter.
• Insert the filter firmly all the way in.

8 Close the maintenance cover and then the front cover.

9 Tap  ([Enter] key) to exit maintenance.
 ["6. End the maintenance" P.151](#)

Before Use

About Maintenance

Basic Operations

Wearing protective equipment

Various settings

Checking ink and replacing ink bag

Maintenance

Emptying waste ink tank

When problems occur

Daily maintenance at the end of work

Appendix

Printer maintenance

Replace the consumable parts

Moving or transporting the printer

Long-term storage

Replace the UV-LED unit glass

The glass of the UV-LED unit is a component to protect the UV-LED unit. Using the printer with dirty or broken glass will cause damage to the lamp or insufficient ink curing. Please replace the glass as needed.



Caution



Wear the protective gloves, glasses and masks and avoid contact with your eyes or skin. Eye or skin contact may cause slight irritation or bloodshot eyes. If in eyes or on skin, immediately flush with water. If irritation is present, seek medical advice/attention immediately.



The UV-LED lamp may get hot after printing. Allow the lamp to cool down for 10 minutes after printing and then start replacement.

Replacement procedure

1

Prepare the necessary items for maintenance.

 ["Preparations for maintenance" P.131](#)

What you need:

- Polyethylene gloves, Rubber gloves, Protective goggles, Protective mask
- Replacement Glass

2

Wear protective equipment.

 ["Wearing protective equipment" P.132](#)

3

Put the printer in CR maintenance state.

 ["Menu 11: CR Maintenance" P.123](#)

4

Open the front cover.

Before Use

About Maintenance

Basic Operations

Wearing protective equipment

Various settings

Checking ink and replacing ink bag

Maintenance

Emptying waste ink tank

When problems occur

Daily maintenance at the end of work

Appendix

Printer maintenance

Replace the consumable parts

Moving or transporting the printer

Long-term storage

5 Open the left maintenance cover.

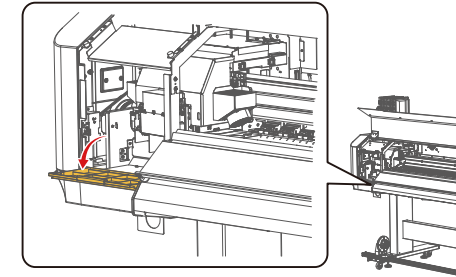

6 Check the glass and replace if there are defects or cracks.

1. Slide the exhaust cover up using the screw on the right side of the exhaust cover as a fulcrum.
2. Slide the glass attached on the bottom of the UV-LED unit to the right to remove it.
3. Check for cracks, chips, or ink on the glass.
4. Attach a new glass to the UV-LED unit. Insert the glass firmly all the way to the back and lower the exhaust cover as before.

Important!

Make sure that the glass is attached to the UV-LED unit and the exhaust cover is put back in place. Using your printer without them will cause damage to the unit.

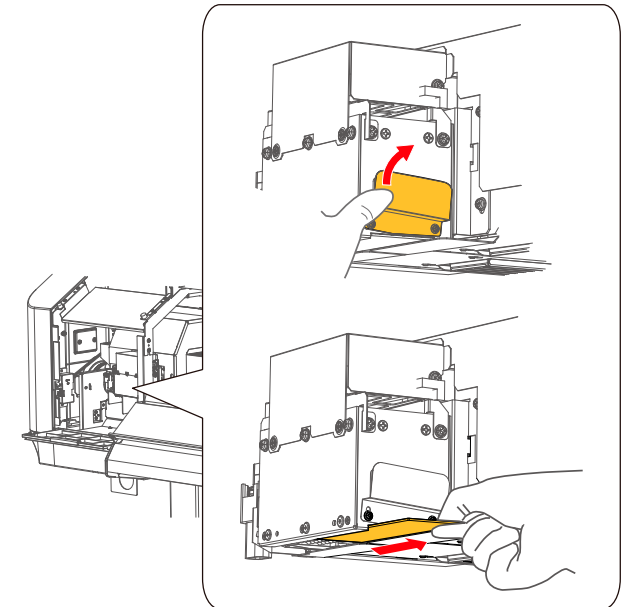

7 Close the maintenance cover and then the front cover.

8 Tap  ([Enter] key) to exit maintenance.

 "6. End the maintenance" P.151

Before Use

About Maintenance

Basic Operations

Wearing protective equipment

Various settings

Checking ink and replacing ink bag

Maintenance

Emptying waste ink tank

When problems occur

Daily maintenance at the end of work

Appendix

Printer maintenance

Replace the consumable parts

Moving or transporting the printer

Long-term storage

Replace the flushing box



Caution



Wear the protective gloves, glasses and masks, and avoid contact with your eyes or skin. Eye or skin contact may cause slight irritation or bloodshot eyes. If in eyes or on skin, immediately flush with water. If irritation is present, seek medical advice/attention immediately.

1

Prepare the necessary items for maintenance.

☞ ["Preparations for maintenance" P.131](#)

What you need:

- Polyethylene gloves, Rubber gloves, Protective goggles, Protective mask
- Replacement flushing box

2

Wear protective equipment.

☞ ["Wearing protective equipment" P.132](#)

3

Put the printer in CR maintenance state.

☞ ["Menu 11: CR Maintenance" P.123](#)

4

Open the front cover.

5

Open the right side maintenance cover.

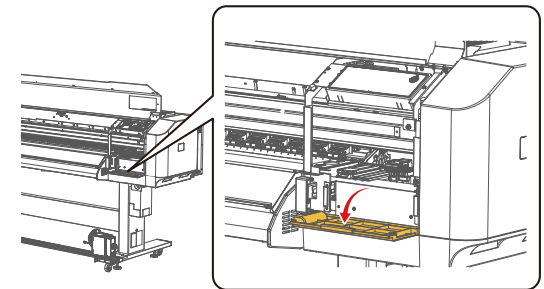

Before Use

Basic Operations

Various settings

Maintenance

When problems occur

Appendix

About Maintenance

Wearing protective equipment

Checking ink and replacing ink bag

Emptying waste ink tank

Daily maintenance at the end of work

Printer maintenance

Replace the consumable parts

Moving or transporting the printer

Long-term storage

- 6 Lift the tabs and tilt the flushing box to drain the waste liquid.

Note

Put the used flushing box in a plastic bag and dispose of it according to the local regulations

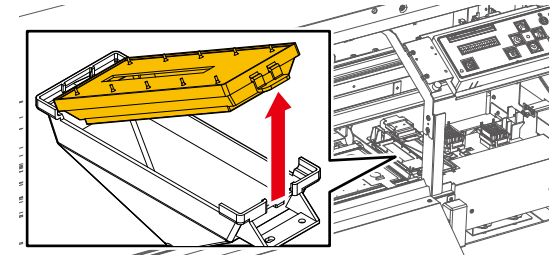

- 7 Install a new flushing box.

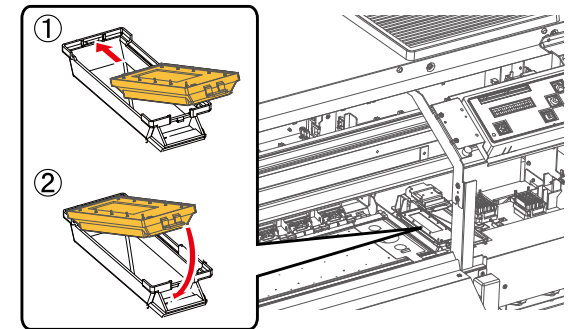

- 8 Fill 30 ml of maintenance cleaner into the flushing box.

Important !

If the maintenance cleaner is spilled on the cover of the flushing box, clean it with a paper towel to avoid splash by a fan.

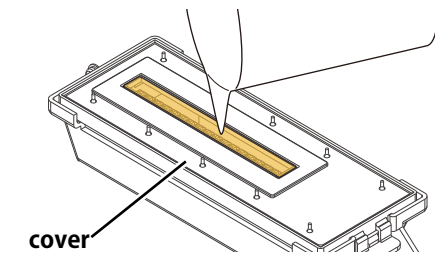

- 9 Close the maintenance cover and then the front cover.

- 10 Tap  ([Enter] key) to exit maintenance.

 "6. End the maintenance" P.151

Before Use	About Maintenance
Basic Operations	Wearing protective equipment
Various settings	Checking ink and replacing ink bag
Maintenance	Emptying waste ink tank
When problems occur	Daily maintenance at the end of work
Appendix	Printer maintenance
	Replace the consumable parts
	Moving or transporting the printer
	Long-term storage

Moving or transporting the printer

Transporting the printer

When transporting this product, it must be repacked in the original packaging and packaging materials as you purchased to protect the printer from vibration and shock.

Important!!
 When transporting this product, please consult your local MUTOH dealer.

Moving the printer

This section explains how to move this product.

Important !!

- Before moving this printer, always empty the waste ink tank even moving short distance. Failure to do so may result in damage to the product.
- Minimum three people are required for moving this product. When moving, keep the product level. Otherwise proper operation cannot be guaranteed after moving.
- Wearing safety shoes is recommended for moving this product.

Before Use

About Maintenance

Basic Operations

Wearing protective equipment

Various settings

Checking ink and replacing ink bag

Maintenance

Emptying waste ink tank

When problems occur

Daily maintenance at the end of work

Appendix

Printer maintenance

Replace the consumable parts

Moving or transporting the printer

Long-term storage

Preparation for moving the printer

- 1 Turn off the power.
☞ "Turn off the printer" P.44
- 2 Empty the waste ink tank.
☞ "Emptying waste ink tank" P.138
- 3 Disconnect all cables, including the power cord.
- 4 Loosen the adjusters (4 places) on the stand by rotating them counterclockwise.
- 5 Move the printer.

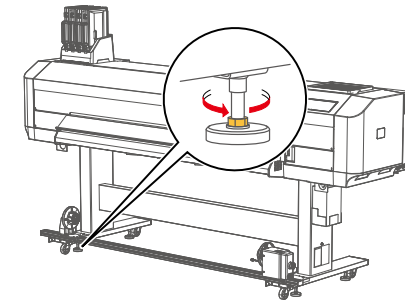

Before Use	About Maintenance
Basic Operations	Wearing protective equipment
Various settings	Checking ink and replacing ink bag
Maintenance	Emptying waste ink tank
When problems occur	Daily maintenance at the end of work
Appendix	Printer maintenance
	Replace the consumable parts
	Moving or transporting the printer
	Long-term storage

After moving the printer

- 1
 Select a suitable location for installation.
☞ [Getting Started Guide](#)
- 2
 After moving the printer to the installation site, use the adjusters to lock the printer.
- 3
 Connect the cables including the power cord.
- 4
 Run a nozzle check to make sure all nozzles are clear.
☞ ["Performing Nozzle Check" P.61](#)
- 5
 Perform "Print quality calibration (Adjust Print)".
☞ ["Print quality calibration \(Adjust Print\)" P.97](#)

Before Use

About Maintenance

Basic Operations

Wearing protective equipment

Various settings

Checking ink and replacing ink bag

Maintenance

Emptying waste ink tank

When problems occur

Daily maintenance at the end of work

Appendix

Printer maintenance

Replace the consumable parts

Moving or transporting the printer

Long-term storage

Long-term storage

Long-term storage

When the printer is not in use for an extended period of time, perform the "Longstore" cleaning to flush ink out of the printer for storage.

["Longstore" P.95](#)

1 Prepare the necessary items for long-term storage.

["Preparations for maintenance" P.131](#)

What you need:

- Cleaning bag: 4 pcs.

2 Access the Longstore menu.

1. Tap ([Home] key). "Setup" will be displayed.
2. Tap key to display "User Type".
3. Tap / key to display "Longstore".
4. Tap key to display "Start" -> Enter".

3 Tap ([Enter] key).

- Use or key to select "Yes".

Prepare Cleaning Bag

NO

4 Empty the waste ink tank, then tap [Enter] key.

["Emptying waste ink tank" P.138](#)

Empty Waste Ink Tank

-> Enter

5 Tap ([Enter] key).

- Use or key to select "Yes".

Empty the Tank ?

NO

6 Tap [Enter] to start cleaning.

- "Remove Bags" will appear.
 1. Remove all ink bag cases and smartchip cards.
 - Once removed, the printer begins flushing ink out of the printer.

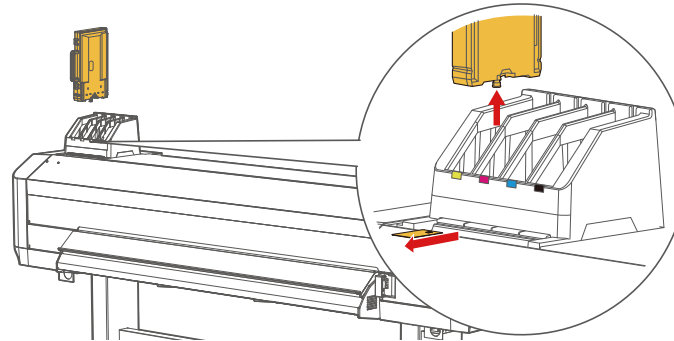

2. Store the ink bags with the corresponding smartchip cards.
3. When ink flushing is completed, "Insert Cleaning Bags" will appear.

7 Place the cleaning bag in the ink bag case.

1. Unlock the latches (x 4) and open the ink bag case.

Important!

Do not apply excessive force when unlocking the latch. This may cause damage to the latch.

2. Place the cleaning bag in the ink bag case.

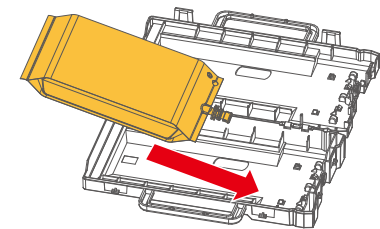
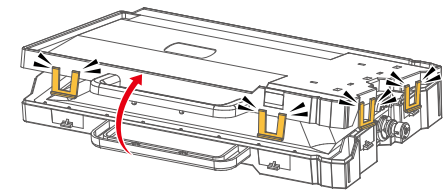

Before Use

About Maintenance

Basic Operations

Wearing protective equipment

Various settings

Checking ink and replacing ink bag

Maintenance

Emptying waste ink tank

When problems occur

Daily maintenance at the end of work

Appendix

Printer maintenance

Replace the consumable parts

Moving or transporting the printer

Long-term storage

3. Close the ink bag case.

Important!

Make sure that the spout of the cleaning bag is properly fitted into the groove in the case. If not fitted, the printer cannot detect the cleaning bag correctly.

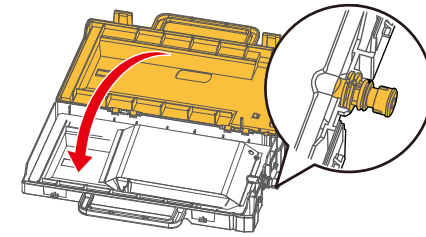

4. Lock the latches (x 4) firmly.

Important!!

Check that all the latches (x 4) are closed. If not, it may cause cleaner spillage.

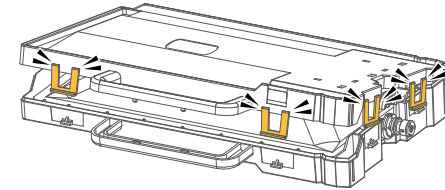

8

Insert the ink bag case and smartchip card into the ink slot.

1. Face the latch side towards you and insert the case into the slot.
 - Make sure that they are fully inserted.
 - Once loaded, the printer begins head cleaning.

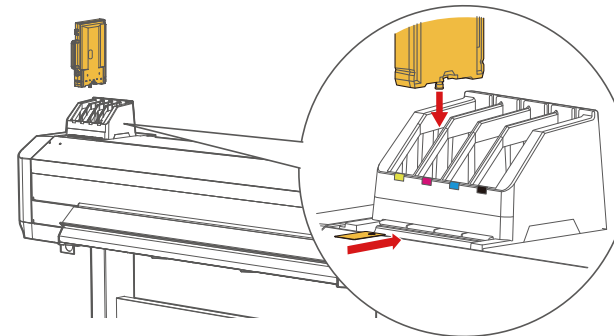

2. Once the printer is filled with the cleaner, "Remove Bags" will be displayed.

Before Use

Basic Operations

Various settings

Maintenance

When problems occur

Appendix

About Maintenance

Wearing protective equipment

Checking ink and replacing ink bag

Emptying waste ink tank

Daily maintenance at the end of work

Printer maintenance

Replace the consumable parts

Moving or transporting the printer

Long-term storage

9 Remove the ink bag case and smartchip card from the ink slot.

1. Remove all ink bag cases and smartchip cards.
 - Once removed, it begins flushing cleaner out of the printer.
2. Store the cleaning bag with the corresponding the smartchip card.
3. When the cleaner has been drained, "Insert Cleaning Bag" is displayed.

10 Repeat steps 8-9 several times.

- The message on the right will appear.

[KCMY] Discharged

11 Turn off the printer.

- ☞ ["Turn off the printer" P.44](#)

Before Use	About Maintenance
Basic Operations	Wearing protective equipment
Various settings	Checking ink and replacing ink bag
Maintenance	Emptying waste ink tank
When problems occur	Daily maintenance at the end of work
Appendix	Printer maintenance
	Replace the consumable parts
	Moving or transporting the printer
	Long-term storage

Initial ink charging after Longstore cleaning

Caution

Do not perform any of the following operations while ink is being loaded

- Turn off the printer or unplug the power cord
- Open the front cover or maintenance cover
- Raise the pressure rollers
- Move the printer

1 Turn on the printer.
 Tap ("Turn on the printer" P.43)

2 Tap ([Enter] key) to start ink filling.

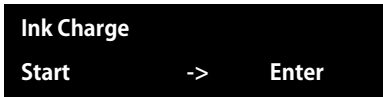

3 Tap ([Enter] key).



Note

If you need to wash the head, tap the key to select "Wash Retry? Yes" and tap [Enter]. Then follow the instructions on the printer control panel.
 When cleaning is complete, "Insert Ink Bags" will be displayed. Go to step 4.

4 Tap ([Enter] key) to start ink filling.
 • "Insert Ink Bags" appears.

Before Use

About Maintenance

Basic Operations

Wearing protective equipment

Various settings

Checking ink and replacing ink bag

Maintenance

Emptying waste ink tank

When problems occur

Daily maintenance at the end of work

Appendix

Printer maintenance

Replace the consumable parts

Moving or transporting the printer

Long-term storage

5 Agitate the ink in a new ink bag.

1. Hold the ink bag with the ink outlet facing up and wait for three seconds.
2. Invert it with the ink outlet facing down and wait for three seconds.
3. Repeat this 3 times.

Important!!

Be sure to use a new ink bag.
If a used ink bag does not have enough ink, it will run out of ink during initial ink charging and will consume more ink.

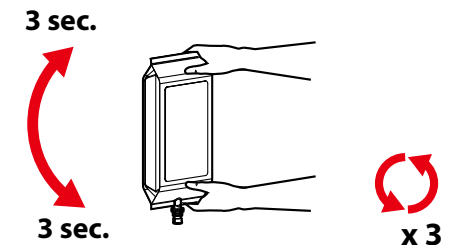

6 Put the ink bag into the ink bag case.

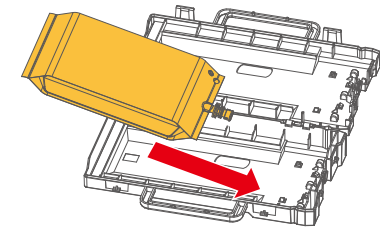

7 Close the ink bag case.

- Make sure that the spout of ink bag is properly fitted into the groove in the case.

Important!

If not fitted, the printer cannot correctly detect the ink bag.

- Close the latches (x 4) of the case properly.

Important!

If not, it may cause ink spillage.

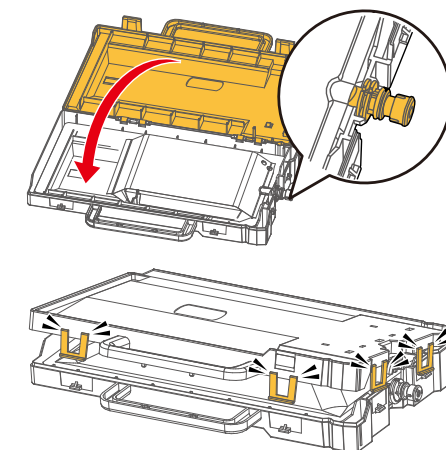

Before Use

About Maintenance

Basic Operations

Wearing protective equipment

Various settings

Checking ink and replacing ink bag

Maintenance

Emptying waste ink tank

When problems occur

Daily maintenance at the end of work

Appendix

Printer maintenance

Replace the consumable parts

Moving or transporting the printer

Long-term storage

8

Insert the ink bag case and smartchip card into the ink slot.

- Match the color of the label on the printer with the color of the label on the ink bag.
 1. Face the latch side towards you and insert the case into the slot.
 - Make sure that they are fully inserted.
 - Once loaded, ink charging begins.

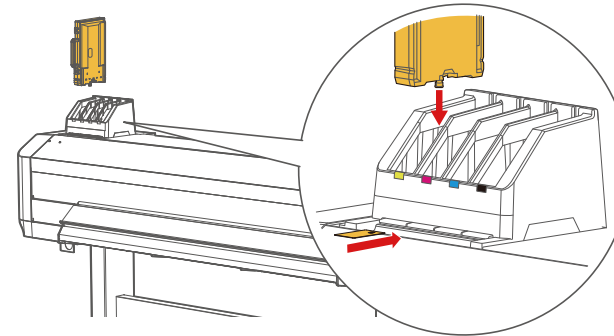

2. When ink charging is completed, "Media End" is displayed.

Important!!

If you run a nozzle check print immediately after the initial ink charging, the following symptoms may occur.

- Lines are faded.
- Patterns are partially missing.

In such cases, perform Little Charge according to "[Menu 3: Cleaning](#)" P.111 and then check the printed results.

If it does not help to solve the problem, leave the printer for at least one hour, then perform cleaning or "Little Charge" cleaning again. If the problem still persists, please contact your local MUTOH dealer.

When problems occur

Messages and Error Messages 183



Troubleshooting 193

Messages and Error Messages

This section describes the messages that appear and how to deal with them.

Status messages

This section describes the messages when the printer is working properly.

Display	Description
Print Ready	Ready-to-print state (Media is loaded)
Media End	Ready-to-print state (Media is not loaded). 👉 "Load the media into the printer" P.45
Receiving	Data is being received.
Converting	Data analysis is in progress.
Printing	Printing is in progress.
Print Remain: *** m	Displays the length in meters of data that has not yet been printed for the currently printed data.
Remain Time: *** min	Displays the time remaining to print in minutes for the data currently being printed.
Roll Remain: *** m	Displays the remaining length of the currently set roll media in meters.
Pausing Print Cancel Print -> Enter	Printing is being paused. • Tap  ([Cancel] key) to resume printing. • Tap  ([Enter] key) to stop printing.
Canceling	Printing is being canceled.
Feeding Forward	Feeding the media forward.
Feeding Backward	Rewinding the media.
Warming Up	Heater is warming up.
Warming Up Skip -> Enter	To start printing before the heater warms up, tap  ([Enter] key).

Before Use

Basic Operations

Various settings



Maintenance

When problems occur

Appendix

Messages and Error Messages

Troubleshooting

Display	Description
Cleaning **0%	Cleaning in progress. Please wait a moment.
Ink Refill **0%	Charging the Ink. Please wait a moment.
SubTank Refill **0%	Filling ink in the subtank. Please wait a moment.
Washing Head	The cleaning solution is filled and drained in the initial cleaning. Or, the print head is being cleaned in the head cleaning process. Please wait a moment.
User: Type ** OK? Media Initial	Initializing media. Please wait a moment. (* indicates the selected user type)
Move To Origin Position	In the origin setting menu, the print head is moving to the print start position. Please wait a moment.
Confirm Position End -> Enter	The print head has moved to the print start position. Locate and tap  ([Enter] key).
Power Off	Turning off the printer. Please wait a moment.
Insert Ink Bags	Ink filling is in progress. Install the ink bag case.
Insert Cleaning Bags	Head cleaning process in progress. Install the cleaning bag case.
Remove Bags	Head cleaning or ink discharging process is in progress. Remove the ink bag case.
Empty Waste Ink Tank then Tap Enter	The waste ink tank became full during Initial Charge. Empty the waste ink tank and tap  ([Enter] key).
S/C Reading	The smart chip card is being read.
*** Remote Mode *** End -> Enter	Remote panel mode is being executed by MSM or other means. Operations from the printer control panel are not possible while in remote panel mode. Tap  ([Enter] key) to force the remote panel mode to exit.
Roll Remain Error	The remaining media count has reached zero (Stops printing).
Roll Near End: *** m	The remaining media count will soon reach zero. Remaining media capacity is * m.
Life Times [Pump*] OK -> Enter	The pump motor is approaching the end of its service life (Continue operation). Please contact the MUTOH product dealer where you purchased the product or the MUTOH Customer Support Desk.

Before Use

Basic Operations

Various settings



Maintenance

When problems occur

Appendix

Messages and Error Messages





Troubleshooting

Display	Description
Life Times [CR Motor] OK -> Enter	CR motor is nearing the end of its service life (Continue operation). Please contact the MUTOH product dealer where you purchased the product or the MUTOH Customer Support Desk.
Life Times [PF Motor] OK -> Enter	PF motor is nearing the end of its service life (Continue operation). Please contact the MUTOH product dealer where you purchased the product or the MUTOH Customer Support Desk.
PG: **** L: ***mm	When the Roll Kind menu is set to other than Off, the remaining roll length of the selected media is displayed.  "Rollkind" P.118
PG: **** LI: ***mm	When the End Detection menu is set to [Off], an exclamation mark (!) appears on the panel. There is a risk of printing on the platen as the printer does not detect the presence of media.  "Rollkind" P.118

Message type error display and how to deal with it

This section describes the message-type errors and their countermeasures.

Message-type errors appear when some failure occurs during printer operation. The printer control panel may display an error message and stop operation.

Display	Description
Cover Open	Any or all of the covers (front cover, maintenance cover right, maintenance cover left) are open. Close the cover.
Use Lever Lower pressure Rollers	The pressure rollers is raised. Lower the pressure rollers.
Load Media	No media is loaded. Load the media.  "Load the media into the printer" P.45
Undefined Media	Media recognition failed (Operation is stopped). Re-load the media.
Media Slant	Media slanted (Operation is stopped). Re-load the media.
Media Cut Error	Media could not be cut (Operation is stopped). Re-load the media.
End of Roll	The media is gone (Operation is stopped). Load new media.  "Load the media into the printer" P.45
Change Head Gap *** PG: **** W: ***mm	The head height specified in the print data is different from the actual head height. Change to the indicated head height.  "Print head Height" P.73
[****] Ink End	Ink is gone (Operation is stopped). Replace with a new ink bag.  "Replace the ink bag" P.134
[****] No Bag	Ink bag case is not inserted (Operation is stopped). Insert the ink bag case.
[****] No S/C Card	Smart chip card is not inserted (Operation is stopped). Insert the smart chip card.

Before Use

Basic Operations

Various settings



Maintenance

When problems occur

Appendix

Messages and Error Messages

Troubleshooting

Display	Description
[****] S/C Ink Low	Ink is running low (Operation continues). Prepare replacement ink bags.
[****] S/C Ink End	Smart chip card has run out of remaining capacity (Operation is stopped). Replace with a new ink bag.  "Replace the ink bag" P.134
[*] Chg. S/C Card	Replace with a new smart chip card.
[****] Discharged	Ink is not filled. Perform Initial Charge.  "Initial ink charging after Longstore cleaning" P.179
Full WastelnkTank	The waste ink tank has become full (Operation is stopped). Immediately transfer the liquid waste to a container.  "Emptying waste ink tank" P.138
[****] S/C ReadErr	Failed to read smart chip card. Reinsert the smart chip card.
[****] S/C Col.Err	The ink bag case is installed in the wrong ink slot. Install the ink bag case in the correct ink slot.
[****] S/C Ink Err	This type of ink cannot be used with this product. Please contact the MUTOH product dealer where you purchased the product or a MUTOH sales office.
[****] S/C CodeErr	An incorrect ink bag has been inserted. Please contact the MUTOH product dealer where you purchased the product or a MUTOH sales office.
[****] Broken Chip	The smart chip card is damaged. Replace with a new ink bag.
[****] Ink term warns	The ink has expired. Replace with a new ink bag.
[****] Ink Expired	The ink has expired. (Operation is stopped). Replace with a new ink bag.

Before Use

Basic Operations

Various settings









Maintenance

When problems occur

Appendix

Messages and Error Messages

Troubleshooting

Display	Description
Cannot Operate Outside Print Area	Printing is not performed because the width of the printable area is insufficient. The width of the printable area is based on the media width of the loaded media, and is increased or decreased by the amount of change in the CR direction of the origin setting and the amount of change in the side margin (total of left and right).  "Media Width" P.92 , "Origin" P.93 , "Side Margin" P.92 The width of the required printable area varies for each function. Adjust to the appropriate width. <ul style="list-style-type: none">• "Menu 1: Setup menus" P.89 > "Print quality calibration (Adjust Print)" P.97 (over 550 mm)• "Menu 1: Setup menus" P.89 > "Media feed adjustment" P.102 (over 400 mm)• "Menu 2: Test Print" P.106 > "Adjust Head" P.108 (over 550 mm)• "Menu 9: Roll Length Manage" P.117 > "Simple Print" P.117 (over 400 mm)
Cannot Operate Media Initial - Off	The "Roll Length Manage" menu cannot be displayed because the Media Initial is set to "Off". Set the Media Initial to "Top&Width" or "Width" and then select the "Roll Length Manage" menu.  "Media Initial" P.92 ,  "Menu 9: Roll Length Manage" P.117
Cannot Operate Media	No media is loaded. Load the media.  "Load the media into the printer" P.45
Cannot Operate Rollkind Off	Cannot print because the "Roll Length" is set to "Off" and cannot be printed. After setting the "Roll Length", click on the Print menu or the Simple Print menu in the Print menu or the Simplified Print menu.  "Rollkind" P.118  "Print" P.117 ,  "Simple Print" P.117
Cannot Operate Output Mode - Take Up	The scanner cannot be scanned because the Output Mode is set to "Take Up" and cannot be scanned. Set the Output Mode to "Off" and then select the read menu in the read menu.  "Output Mode" P.92 ,  "Scan" P.119

 **Note**

- "Change Head Gap ****" can be either High, Middle or Low.
- The error display [****] indicates the ink bag that is the target of the warning.
- When "Ink End" or "No S/C Card" and "No Bag" occur at the same time, the "No Bag" indication has priority.

Smartchip Recovery

If the following message appears on the printer control panel, a smartchip error such as broken chip may have occurred in the smartchip card.

Check that the correct smartchip card is inserted and perform smartchip recovery. This will allow you to continue to print.

To perform smartchip recovery, do one of the followings according to the message appeared.

Display	Description
[*] S/C Recog. E	The smartchip card that needs smartchip recovery may have been installed. Remove the smartchip card and insert it again. If the printer is still unable to read it, insert a new smartchip card. <ul style="list-style-type: none"> If "[*] Check Color OK -> Enter" is displayed after reinserting the smart chip card, follow the instructions.
[*] Check Color OK -> Enter	The smartchip card that needs smartchip recovery may have been installed. Check that the ink color of the smartchip card inserted is correct. <ul style="list-style-type: none"> In case of wrong color insertion, insert a correct smartchip card. If the correct smart chip card is inserted, tap  ([Enter] key). The printer will perform smartchip recovery and will continue to print.
[*] Chg. S/C Card	The smartchip card that the smartchip recovery was performed has run out of ink. Replace with a new smart chip card.

Note

- [*] in the error message indicates the ink bag that is subject to alert.
- While Smart Chip Recovery is in progress, the target ink will blink in the "Ink Status" menu.

 ["Ink Status" P.113](#)

Error requiring reboot

An error requiring a restart is indicated when the printer experiences a fatal failure in its operation, such as

- When obstacles that interfere with driving occur
- If an electrical circuit (board, motor, sensor, etc.) fails
- When an abnormality occurs in the control program

If this error occurs, the printer will stop operation after

1. Automatically shuts off power of the drive system.
2. All the LEDs on the printer control panel blink and the buzzer sounds intermittently.
3. Error message appears in the printer control panel.

- Tap any key on the printer control panel to stop the buzzer sound.
- For this kind of error, the printer will be recovered by removing the cause of the error and restarting the printer.
- If the same error message appears again, please contact the MUTOH dealer you purchased your printer from or the MUTOH Customer Support Center. When contacting us, please be sure to provide the code number of the error message.

Display	Causes and remedies
E016 xxxxxxxx[xx]	A problem was detected with the control program. 1. Turn off the power on the machine and turn it on after a while.
CPU ERROR [35]	A problem was detected with the control PCB. 1. Turn off the power on the machine and turn it on after a while.
E065 ERROR PF Motor	A problem was detected during motor control. 1. Turn off the power on the machine and turn it on after a while.
E066 ERROR CR Motor	
E067 ERROR PF Encoder	
E068 ERROR CR Encoder	
E069 ERROR PF Timeout	
E070 ERROR CR Timeout	

Before Use

Basic Operations

Various settings

Maintenance

When problems occur

Appendix

Messages and Error Messages

Troubleshooting

Display	Causes and remedies
E071 ERROR PF Current	Overcurrent or overload was detected during motor operation.
E072 ERROR CR Current	1. Open the front cover and check for any obstructions to carriage operation.
E073 ERROR PF2 Current	2. Check if the media is loaded correctly.
E074 ERROR CR2 Current	3. Turn off the power on the machine and turn it on after a while.
E076 ERROR Pre Heat	A problem was detected with the heater control.
E077 ERROR Platen Heat	1. Turn off the power on the machine and turn it on after a while.
E078 ERROR Dryer	
E079 ERROR Board Commu.	A problem was detected with the communication between the control PCBs.
	1. Turn off the power on the machine and turn it on after a while.
E081 ERROR CR Origin	A problem was detected during the origin detection.
	1. Turn off the power on the machine and turn it on after a while.
E090 ERROR Heater Volt	A problem was detected with the heater voltage.
	1. Turn off the power on the machine and turn it on after a while.
E092 ERROR CR Over Load	The CR motor was overloaded.
	1. Turn off the power on the machine and turn it on after a while.
E093 ERROR Control Ver.	Control PCB version mismatch was detected.
	1. Turn off the power on the machine and turn it on after a while.
E097 ERROR NVRAM	A problem was detected with the parameter.
E126 ERROR VBS 1	1. Turn off the power on the machine and turn it on after a while.
E127 ERROR VBS 2	
E13x ERROR SubTank x	A problem was detected with the sub-tanks in the ink supply path.
	1. Turn off the power on the machine and turn it on after a while.
E140 ERROR Pre Therm.	A problem was detected with the heater temperature.
E141 ERROR PlatenTherm.	1. Turn off the power on the machine and turn it on after a while.
E142 ERROR Dryer Therm.	

Before Use

Messages and Error Messages

Basic Operations

Troubleshooting

Various settings

Maintenance

When problems occur

Appendix

Display	Causes and remedies
E186 ERROR Head Temp 1	A problem was detected with the head temperature. 1. Turn off the power on the machine and turn it on after a while.
E187 ERROR Head Temp 2	
E188 ERROR Head Heat 1	
E189 ERROR Head Heat 2	
E190 ERROR H Trans Th.1	
E191 ERROR HTrans Th.2	
E228 ERROR UV Fan1	A problem was detected with in the fan for cooling the UV-LED unit. 1. Turn off the power on the machine and turn it on after a while.
E229 ERROR UV Fan2	
E231 ERROR UV HeadDet.	UV-LED unit are not yet installed. 1. Turn off the power on the machine and turn it on after a while.
E232 ERROR Wiper Sensor	A problem was detected in the operation of the cleaning wiper. 1. Check if there are any obstructions to interrupt cleaning wiper operation. 2. Turn off the power on the machine and turn it on after a while.
E233 ERROR Wiper Motor	

Troubleshooting



This section describes printer troubles that an error message is not prompted, and possible cause and solutions.

Note

- Printer status and error information can be checked from MSM status information. If the printer is not working properly, please check the MSM.
- Please use the latest version of MSM. You can check the version information in MSM's help to see if there is a newer version than your MSM. If old version is installed in your computer, download the latest version from MUTOH Club.

 [MUTOH Status Monitor](#)

Trouble during installation / initial setup

Symptoms	Possible cause and Remedy
Cannot perform initial ink charging.	Check that the front cover and the maintenance cover are closed.
	Check that the pressure rollers are down.
	Make sure that ink bag cases and smartchip cards are all the way seated in the slots.  "Load a new ink bag" P.136
Ink does not come out after Initial Charge.	Check that the ink bag is not too cold. <ul style="list-style-type: none"> • Rest the ink bags for at least 3 hours at room temperature, and then perform head cleaning several times.  "Nozzle check and head cleaning" P.152
	Is the power turned OFF during ink charging? <ul style="list-style-type: none"> • Turn the power ON and perform an initial ink charging again.
Nozzle clogging occurs after initial ink charging.	Perform cleaning and then check the print results.  "Nozzle check and head cleaning" P.152 <ul style="list-style-type: none"> • If there is no improvement in the print result even after performing cleaning, leave the printer unused for an hour or more. Then perform cleaning or "Little Charge" again and check the print result. If the problem still persists, contact your local Mutoh dealer.

Before Use

Messages and Error Messages

Basic Operations

Troubleshooting

Various settings

Maintenance

When problems occur

Appendix

Symptoms	Possible cause and Remedy
Unable to connect to printer from MSM or RIP	Check that the Ethernet cable is connected securely to the Ethernet port.
	Check that the network settings are configured correctly.
	Check that the printer's network settings match with the computer's settings. ☞ "Menu 7: Initial Settings" P.115 ☞ "IP Address" P.115 , ☞ "Subnet Mask" P.115 , ☞ "Gateway" P.115

Before Use

Messages and Error Messages

Basic Operations

Troubleshooting



Various settings

Maintenance

When problems occur

Appendix

Trouble with operation

Symptoms	Possible cause and Remedy
Printer does not work at all after powered on or even after media is loaded.	Check that the power cord is connected correctly.
	Does the AC power supply provide the specified voltage? <ul style="list-style-type: none">• Connect to another outlet.
	Check that the front cover and the maintenance covers are closed.
	Check that the pressure rollers are down
	Check that the media is loaded into the printer correctly.  "Load the media into the printer" P.45
	Check that the ink bag cases are inserted into the ink slots.
	Do you use the printer within recommended environmental conditions? <ul style="list-style-type: none">• Make sure to use the printer within the specification range.  "Confirm installation location" Getting Started Guide
	Is there an error displayed in MSM? <ul style="list-style-type: none">• Check MSM status information.

Before Use

Messages and Error Messages

Basic Operations

Troubleshooting







Various settings

Maintenance

When problems occur

Appendix

Media-related problems

Symptoms	Factors and Countermeasures
Media detached, torn, or wrinkled during media initials	Check that the media is loaded into the printer correctly.  "Load the media into the printer" P.45
	Are there any foreign materials such as torn paper adhering to the pressure roller? • Clean the pressure roller.  "Cleaning inside the printer" P.155
	Do you use the printer within recommended environmental conditions? • Make sure to use the printer within the specification range.  "Confirm installation location" Getting Started Guide
	Are any curls or warps present on your media? • Place the edge holders on both ends of the media. • Check that you select the appropriate vacuum fan setting.  "5. Procedure after media set" P.55  "Menu 1: Setup menus" P.89 > "Vacuum Fan" P.90
	Are you using folded, scratched, torn, and winding curled media? • Replace the media.
	Is holddown pressure adequate for the roll media? • Try using the slide lock levers on the pressure rollers to individually reduce or cancel the pressurization.  "Canceling or reducing pressure rollers individually" P.76

Note

Remove jammed or torn media according to ["In case of media jam" P.202](#) .

Before Use

Messages and Error Messages

Basic Operations

Troubleshooting

Various settings

Maintenance

When problems occur

Appendix

Symptoms	Possible cause and Remedy
Media initials do not correctly identify media	Check that the media is loaded into the printer correctly. 👉 "Load the media into the printer" P.45
	Is the media set at an angle? • Load the media straight. 👉 "Load the media into the printer" P.45
	Do you use the printer within recommended environmental conditions? • Make sure to use the printer within the specification range. 👉 "Confirm installation location" Getting Started Guide
	Are you using media that has been printed before? • Use new media.
Frequent media jams.	Do you use the printer within recommended environmental conditions? • Make sure to use the printer within the specification range. 👉 "Confirm installation location" Getting Started Guide
	Are any curls or warps present on your media? • Place the edge holder on both ends of the media. • Check that you select the appropriate vacuum fan setting. 👉 "5. Procedure after media set" P.55 👉 "Menu 1: Setup menus" P.89 > "Vacuum Fan" P.90
	Are you using folded, scratched, torn, and rolled media? • Replace the media.

 **Note**

Remove jammed or torn media according to ["In case of media jam" P.202](#) .

Symptoms	Possible cause and Remedy
Media skews during printing	Check that the media is loaded into the printer correctly. 👉 "Load the media into the printer" P.45

Before Use

Basic Operations

Various settings

Maintenance



When problems occur

Appendix

Messages and Error Messages

Troubleshooting

Printing problems

Symptoms	Possible cause and Remedy
Data is sent but not printed.	<p>Check that the Ethernet cable is connected securely to the Ethernet port.</p> <p>Is there any error message displayed on MSM?</p> <ul style="list-style-type: none">• Check MSM status information.
Carriage pauses at right or left edge during printing	<p>Does your computer meets the following requirements?</p> <ul style="list-style-type: none">• OS: Windows 11, Windows 10• CPU: Intel (R) Core (TM) i5 or higher• Memory: 8 Gbytes or more• Network: Gigabit Ethernet-capable network port, using Category 6 or later Gigabit-capable Ethernet cable <div data-bbox="1167 624 2119 831"><p> Note</p><ul style="list-style-type: none">• The OS support period of MUTOH software follows the Microsoft support lifecycle policies.• When using RIP software, please also see the system requirements of your RIP software.</div> <p>Are you using a Gigabit-capable Ethernet cable to make the connection?</p> <ul style="list-style-type: none">• Use a Gigabit-capable Ethernet cable of Category 6 or higher to connect the printer to the computer. <p>Is the MPS function enabled?</p> <ul style="list-style-type: none">• Check the settings of the MPS function.  "MPS" P.85• When set to "On": Check that your computer (specification, CPU load), Ethernet cable (specification, connectivity) and network environment meet the requirements.• When set to "Off": In MSM, the checkbox "MUTOH Print Server (MPS)" is unchecked or "MPS Optimization" is set to "Disable". Try enabling MPS in MSM. <div data-bbox="1167 1222 2119 1326"><p> Note</p><p>Settings for the MPS function can be changed from the MSM.</p></div>

Before Use

Messages and Error Messages

Basic Operations

Troubleshooting

Various settings

Maintenance

When problems occur

Appendix

Symptoms	Factors and Countermeasures
Printing is partially smudged or missing.	Are any curls or warps present on your media? <ul style="list-style-type: none">Place the edge holder on both edges of the media.Check that you select the appropriate vacuum fan setting. ☞ "5. Procedure after media set" P.55 ☞ "Menu 1: Setup menus" P.89 > "Vacuum Fan" P.90
	Is the media deformed by heat? <ul style="list-style-type: none">If the media is deformed by heat during standby, increase the feed amount from the Start Feed menu. ☞ "Menu 1: Setup menus" P.89 > "Start Feed" P.96
	Does the media contain moisture or are you using the creased or wrinkled media? <ul style="list-style-type: none">Replace with new media.
	Is the parts around the print head clean? <ul style="list-style-type: none">Perform cleaning of the outer circumference of the print head. ☞ "3. Clean the parts around the print head" P.146
Printing is misaligned or there are areas that do not print.	Check that the media is loaded into the printer correctly. ☞ "Load the media into the printer" P.45
	Have you set the origin? <ul style="list-style-type: none">Cancel or reset the origin setting. ☞ "Menu 1: Setup menus" P.89 > "Origin" P.93
Printed lines bleed.	Are you printing on the printed side of the media? <ul style="list-style-type: none">Check the print side of the media and set it correctly.
	Did you perform "Print quality calibration (Adjust Print)"? <ul style="list-style-type: none">Perform "Print quality calibration (Adjust Print)". ☞ "Menu 1: Setup menus" P.89 > "Print quality calibration (Adjust Print)" P.97
	Did you perform Media feed adjustment? <ul style="list-style-type: none">Perform Media feed adjustment. ☞ "Menu 1: Setup menus" P.89 > "PF Adjust" P.90

Before Use

Messages and Error Messages

Basic Operations

Troubleshooting

Various settings

Maintenance

When problems occur

Appendix

Symptoms	Factors and Countermeasures
White or black line appears on the print.	Check that the media is loaded into the printer correctly. ☞ "Load the media into the printer" P.45
	Does the media contain moisture or are you using the creased or wrinkled media? • Replace with new media.
	Is the nozzle in good condition? • Perform a nozzle check. • If the nozzle is clogged, perform head cleaning. ☞ "Nozzle check and head cleaning" P.61
	Did you perform "Print quality calibration (Adjust Print)"? • Perform "Print quality calibration (Adjust Print)". ☞ "Menu 1: Setup menus" P.89 > "Print quality calibration (Adjust Print)" P.97
	Did you perform media feed adjustment? • Perform a media feed adjustment. ☞ "Menu 1: Setup menus" P.89 > "Media feed adjustment" P.102
Printing lines are not aligned/doubled, Printed results are blurred.	Is the nozzle in good condition? • Perform a nozzle check. • If the nozzle is clogged, perform head cleaning. ☞ "Nozzle check and head cleaning" P.61
	Did you perform "Print quality calibration (Adjust Print)"? • Perform "Print quality calibration (Adjust Print)". ☞ "Menu 1: Setup menus" P.89 > "Print quality calibration (Adjust Print)" P.97
	Did you perform media feed adjustment? • Perform a media feed adjustment. ☞ "Menu 1: Setup menus" P.89 > "Media feed adjustment" P.102
	Is the ink bag within its expiration date? • Use ink bags that are within the expiration date.

Before Use

Basic Operations

Various settings

Maintenance

When problems occur

Appendix

Messages and Error Messages

Troubleshooting

Symptoms	Factors and Countermeasures
Printed color is not accurate.	Is the nozzle in good condition? <ul style="list-style-type: none">• Perform a nozzle check. If the nozzle is clogged, perform head cleaning. ☞ "Nozzle check and head cleaning" P.61
	Did you install ink ink bags and smartchip cards in the printer in correct color combination? <ul style="list-style-type: none">• If the combination is incorrect, perform "Longstore" cleaning, then an initial ink charging.
Nozzle clogging remains after head cleaning.	Are the cleaning wipers and the parts around the print head clean? <ul style="list-style-type: none">• Clean the cleaning wiper and the parts around the print head. ☞ "4. Clean the cleaning wiper and the parts around the capping unit" P.147 ☞ "3. Clean the parts around the print head" P.146
	Did you select an appropriate cleaning option? <ul style="list-style-type: none">• Head Select: Select "all" or heads with clogged nozzles. ☞ "Menu 3: Cleaning" P.111• Cleaning mode selection: If the nozzle clogging is not resolved after 2 or 3 times of Normal or Long cleaning, perform Little Charge. ☞ "Menu 3: Cleaning" P.111
	Is it time to replace cleaning wipers or the pad for the flushing box? <ul style="list-style-type: none">• Check the conditions of cleaning wiper and flushing box pad and replace them if required. ☞ "About Maintenance" P.129 ☞ "Cleaning Wiper" P.157
Ink does not dry easily after printing	Are you using a heater? <ul style="list-style-type: none">• Check the heater settings. ☞ "Menu 1: Setup menus" P.89 > "Preheater" P.90 , "Platen Heater" P.90 , "Dryer" P.90 ,

 **Note**

- When printing that uses a lot of ink, there is a risk that the ink may not dry easily after printing.
- Depending on the media you are using, the ink may not dry easily.

Before Use

Basic Operations

Various settings

Maintenance

When problems occur

Appendix

Messages and Error Messages

Troubleshooting

In case of media jam

When the media is jammed in the printer, follow these steps to remove it.

1 Turn on the printer.
☞ "Turn off the printer" P.44

2 Open the front cover.

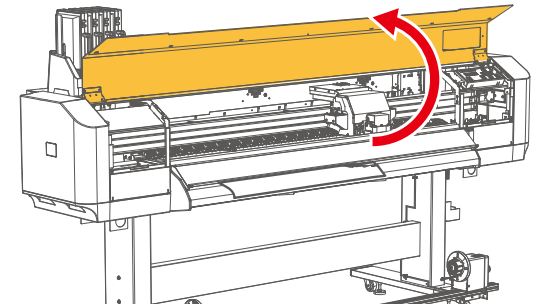

3 Move the carriage from the top of the media to the right side.

Important!!

When the head height is set to Low or Middle, change it to High and then move the carriage. After moving, change the head height back to Low or Middle.

☞ "Print head Height" P.73

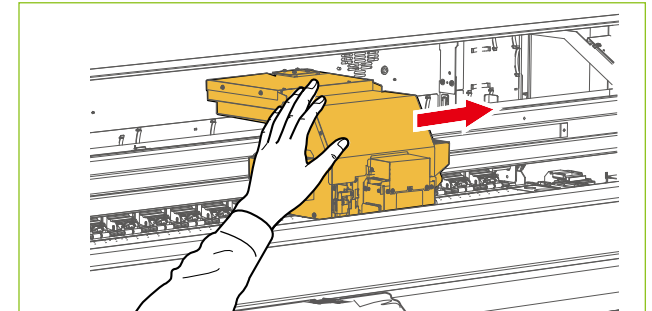

Before Use

Messages and Error Messages

Basic Operations

Troubleshooting

Various settings

Maintenance

When problems occur

Appendix

- 4 Remove the edge holder from the media.

Important!!

If the edge holder is deformed, stop using the printer and contact your local MUTOH dealer.

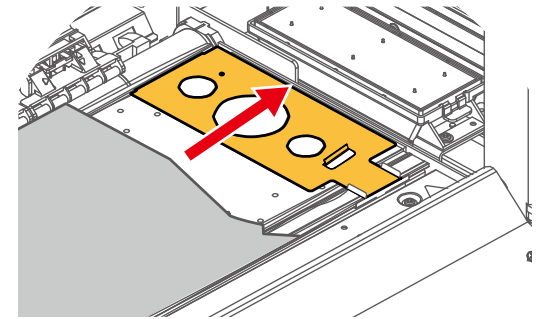

- 5 Raise the pressure rollers.

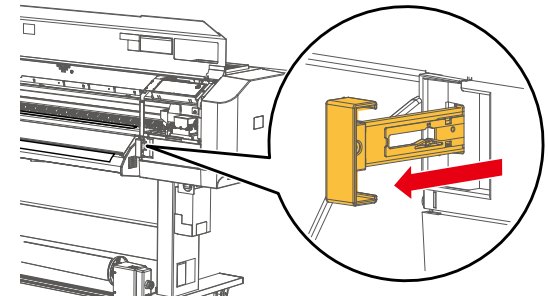

- 6 Pull the media toward the front and use a personal cutter to cut the torn part of the media along the groove.

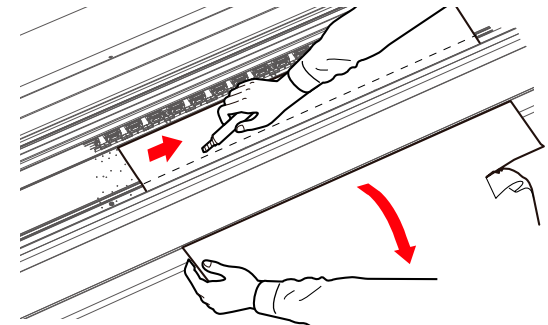

- 7 Turn the flange of the roll media holder to rewind the media onto the roll.

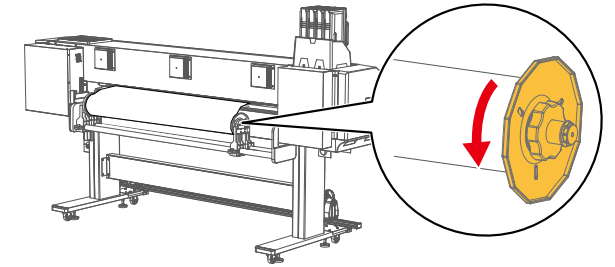

- 8 If paper dust or pieces of paper remain inside the printer, remove them.

- 9 Turn on the printer.
 ☞ "Turn on the printer" P.43

- 10 Load a roll media to print a nozzle check pattern.
 ☞ "Load the media into the printer" P.45

- 11 Tap  key.

- 12 Tap  ([Enter] key).
 • The printer will print the nozzle check pattern F.

Nozzle Check F
 Start -> Enter

- 13 Check the pattern.
 • If the nozzle is clogged, proceed to "Performing Head cleaning" P.63 .
 • If all lines are clearly printed, you can start printing.

Appendix

Specifications 206

Optional accessories / Consumable supplies 209

Revision history 210

Before Use

Basic Operations

Various settings

Maintenance

When problems occur

Appendix

Specifications

Optional accessories / Consumable supplies

Revision history

Specifications

Item	Description	
Model name	HA-1642	
Printing method	On-demand piezo method	
Driving method	Firmware servo / DC motor drive	
Media feed method	Multipoint pressurized grid roller system	
Media hold-down system	Pressure rollers down system with manual lever	
Ink curing system	UV-LED	
Media size	Media outer diameter	Less than 200 mm
	Paper core diameter	2 inch or 3 inch
	Weight	30 kg or less
	Width	500 mm to 1,625 mm
	Recommended media thickness	1.0 mm or less
Maximum printable width	1,615 mm	
Maximum printable length	1,500 m	
Head height adjustment	Low / Middle / High 3-step adjustment	
Interface	Gb-Ethernet (1000BASE-T)	
Waste ink tank	2,000 ml tank attached to the printer	
Ink	Colors	4 colors (black, cyan, magenta, yellow)
	Type	1,000 ml ink bag

Before Use

Specifications

Basic Operations

Optional accessories / Consumable supplies

Various settings

Revision history

Maintenance

When problems occur

Appendix

Item		Description
Environmental Requirements	Operating condition	Temperature: 20 ° C to 32 ° C Humidity: 40 % to 60 %, non condensing
	Printing Condition	Temperature: 22 ° C to 30 ° C Humidity: 40 % to 60 %, non condensing
	Fluctuation	Temperature: No more than 2 ° C per hour Humidity: No more than 5 % per hour
	Printer Storage Condition	<ul style="list-style-type: none">Without ink filled: Within 6 months: Temperature: 10 ° C to 60 ° C Humidity: 20 % to 80 %, non condensingWith ink filled: Within 1 week: Temperature: 10 ° C to 40 ° C Humidity: 20 % to 80 %, non condensing Storage must be within 4 days when stored between 32 ° C to 40 ° C.
	Ink Storage Condition	<ul style="list-style-type: none">Black / Cyan / Magenta / Yellow (1,000 ml each) Temperature: 10 ° C to 40 ° C Humidity: 5 % to 85 %, non condensing Storage must be within one month when stored at 40 ° C. Keep away from heat sources and flammable materials and store in a cool, dark and well-ventilated place.Cleaner bag (300 ml) Temperature: 10 ° C to 40 ° C Humidity: Below 80 %, non condensing Storage must be within one month when stored between 30 ° C and 40 ° C.
Power specifications	Printer:	
	Input voltage	AC 100V to 120V ± 10%. AC 200V to 240V ± 10%.
	Input frequency	50/ 60 Hz ± 1Hz
	Input current	AC 100V to 120V 12.0 A or less AC 200V to 240V 7.0 A or less

Before Use

Basic Operations

Various settings

Maintenance

When problems occur

Appendix

Specifications

Optional accessories / Consumable supplies

Revision history

Item	Description	
Power specifications	Heater: 1	
	Input voltage	AC 100V to 120V \pm 10%. AC 200V to 240V \pm 10%.
	Input frequency	50/ 60 Hz \pm 1Hz
Power specifications	Input current	AC 100V to 120V 10.0 A or less AC 200V to 240V 5.0 A or less
	Take-up unit: 1	
	Input voltage	AC 100V to 240V \pm 10%
Power specifications	Input frequency	50/ 60 Hz \pm 1Hz
	Input current	AC 100V to 240V: 0.26 to 0.13A max.
	Power off	20 W or less
Power consumption	Ready-to-print	240 W or less (When heater is not used)
	Sleep Mode	41 W or less
	Operation	1400 W or less (Peak 2700 W)
Dimensions	Height	1,428 mm When ink bag case (1,000 ml) is installed: 1,611 mm
	Width	2,770 mm
	Depth	895 mm
Weight	Printer body	146 kg
	Stand	32 kg
	Take-up unit	8 kg

Before Use

Basic
Operations

Various
settings

Maintenance

When problems
occur

Appendix

Specifications

Optional accessories /
Consumable supplies

Revision history

Optional accessories / Consumable supplies

For information about optional accessories and consumable supplies, please contact your local MUTOH dealer.

Before Use

Basic Operations

Various settings

Maintenance

When problems occur

Appendix

Specifications

Optional accessories / Consumable supplies

Revision history

Revision history

Date	Version	Manual control number	Supported firmware
2024.07	00	HA1642E-A-00	V.1.00